



南京信息工程大学
NANJING UNIVERSITY OF INFORMATION SCIENCE & TECHNOLOGY

Effect of aging on cloud nucleating properties of atmospheric aerosols

Yan Ma

Nanjing University of Information Science & Technology

The 1st Regional GEOS-Chem Asia Meeting



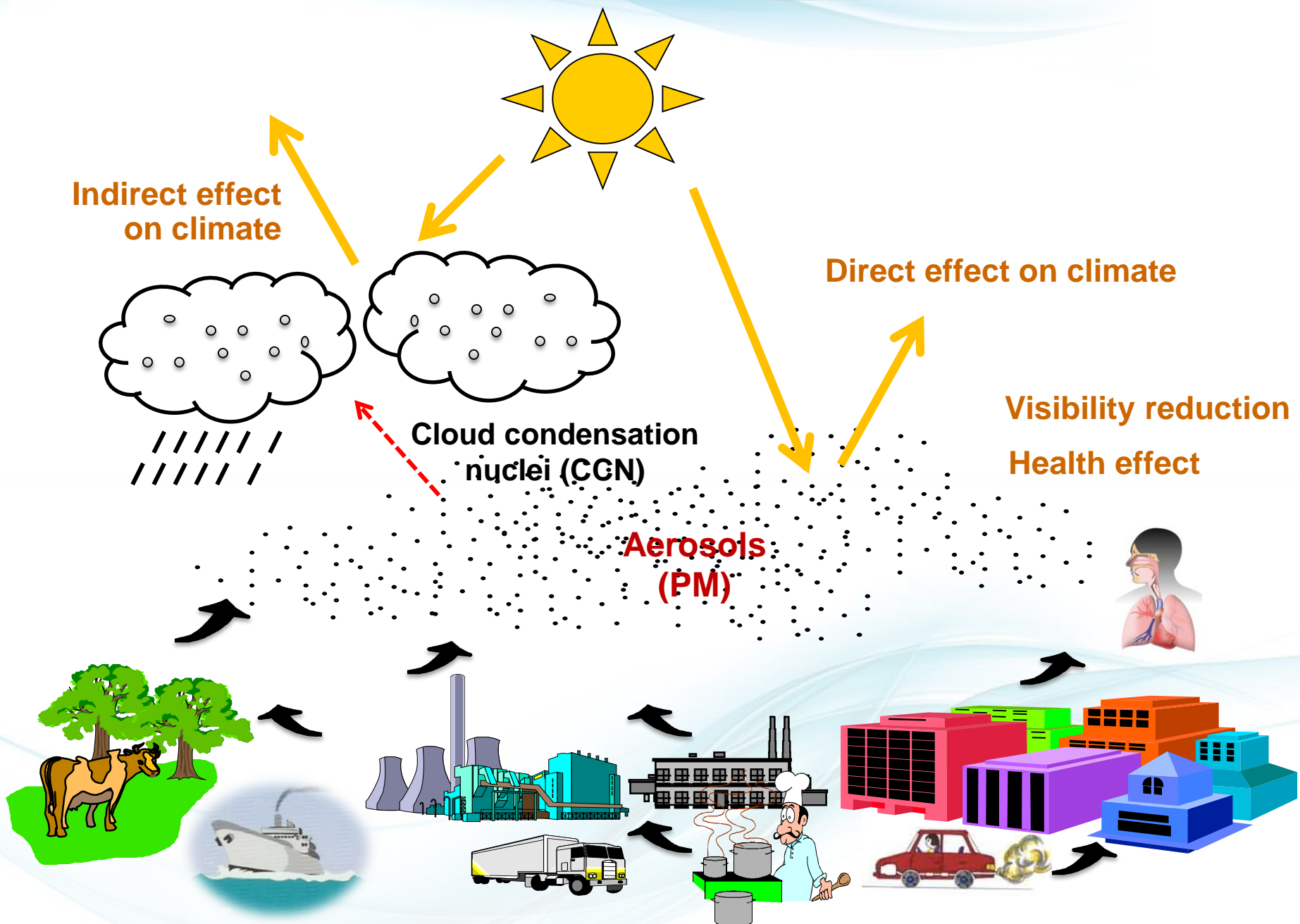

Indirect effect on climate

Direct effect on climate

Cloud condensation nuclei (CCN)

Visibility reduction
Health effect

Aerosols (PM)

Large uncertainty in the estimate of aerosol indirect effects

Global Mean Radiative Forcings from 1750 to 2011
(i.e. Changes in radiation fluxes)

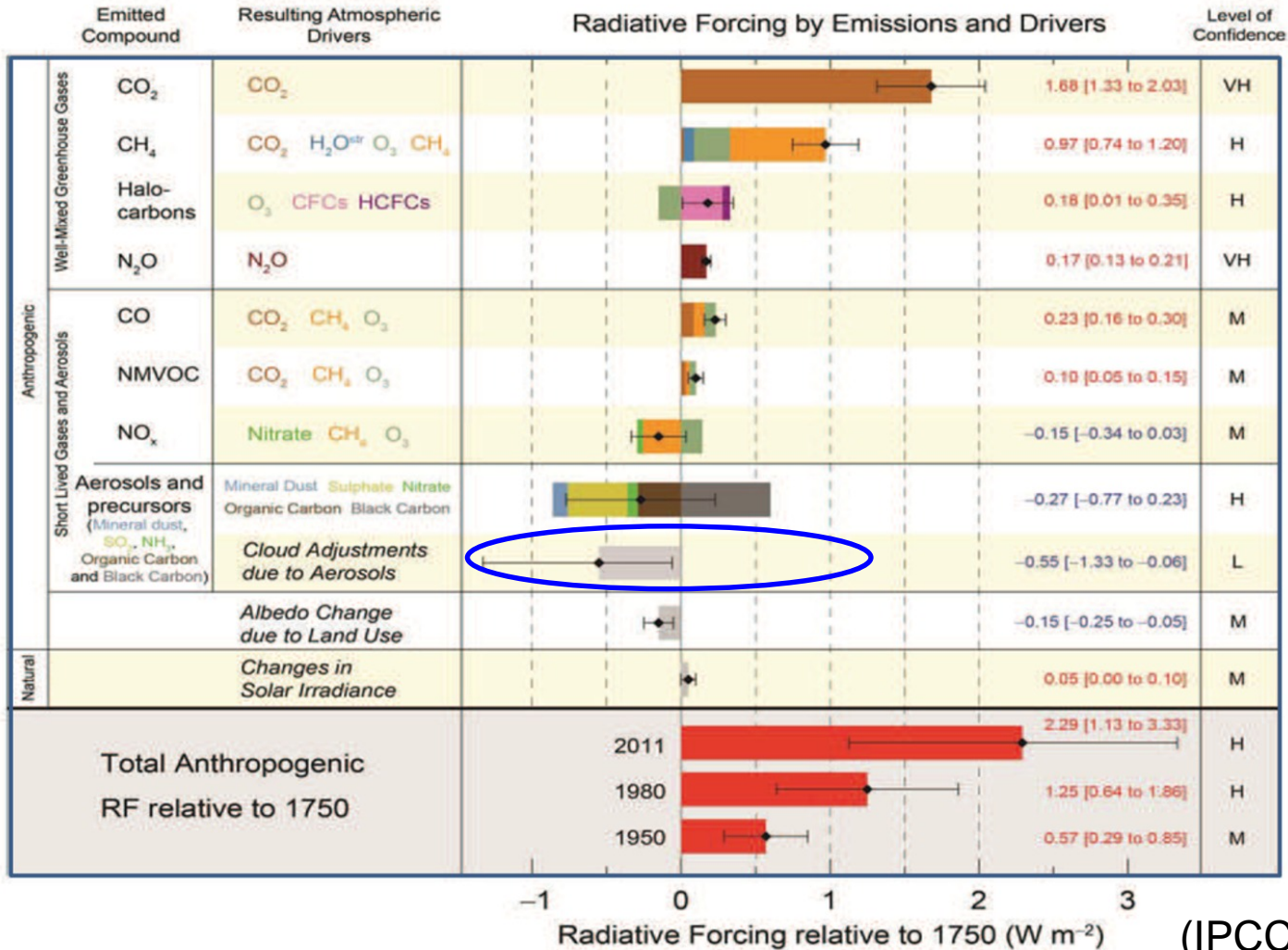

Potential impacts from atmospheric aging of aerosols

- Atmospheric aerosols are often very complex mixtures of many species with a wide range of compositions.
- Aerosols can undergo a variety of aging processes in the atmosphere:
 - Atmospheric aging
 - Condensation of gaseous species, e.g. H_2SO_4 , organics
 - Coagulation with existing aerosol particles
 - Oxidation by OH, O_3 , etc.
 - Aging processes may affect the mixing state, morphology, hygroscopicity, optical properties, and cloud-nucleating abilities

The background of the slide features a light blue and white color scheme with soft, flowing, wavy lines that create a sense of movement and depth. The lines are more prominent at the top and bottom edges, framing the central text.

Lab simulation experiments

Experimental



Smog chamber

- simulate the atmospheric processing of primary aerosol (soot) by oxidation products generated from α -pinene ozonolysis at near-atmospheric conditions (~ 20 ppb O_3 and 7-37 ppb α -pinene)

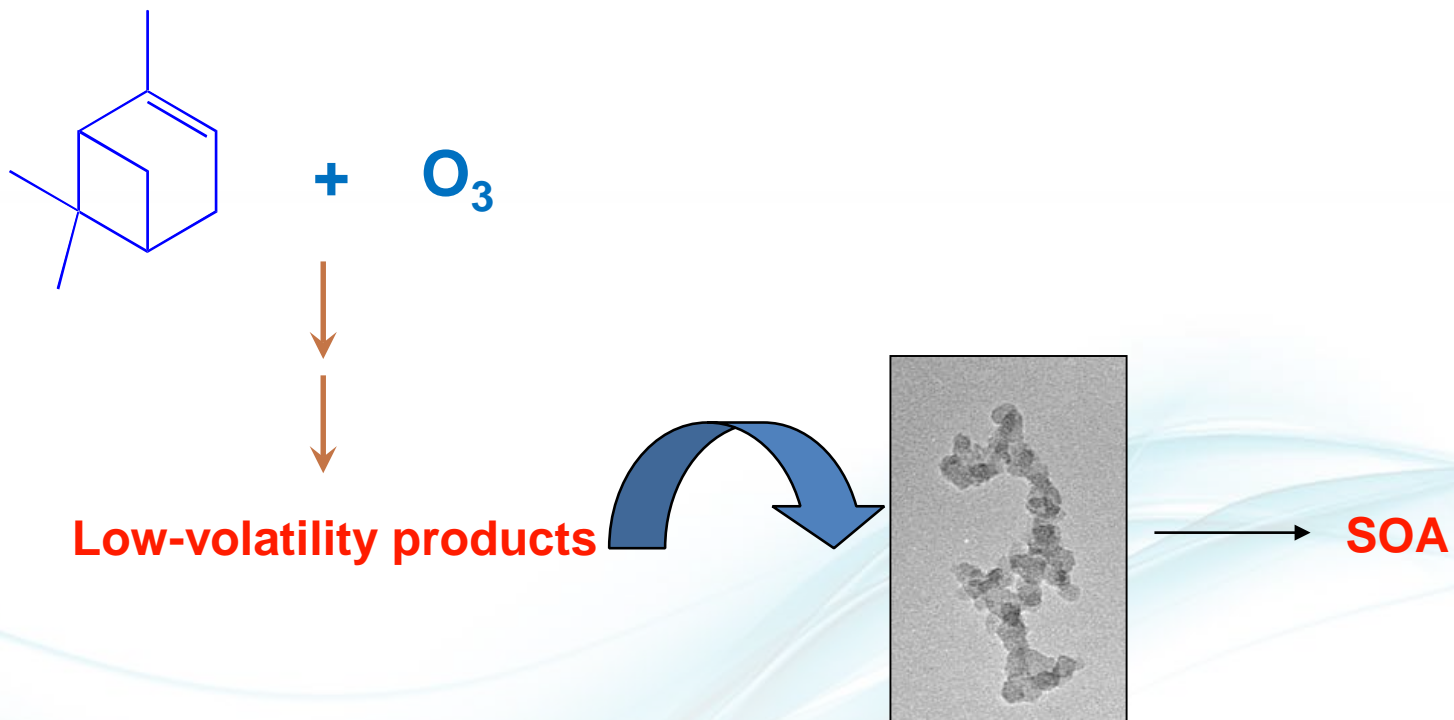

Experimental

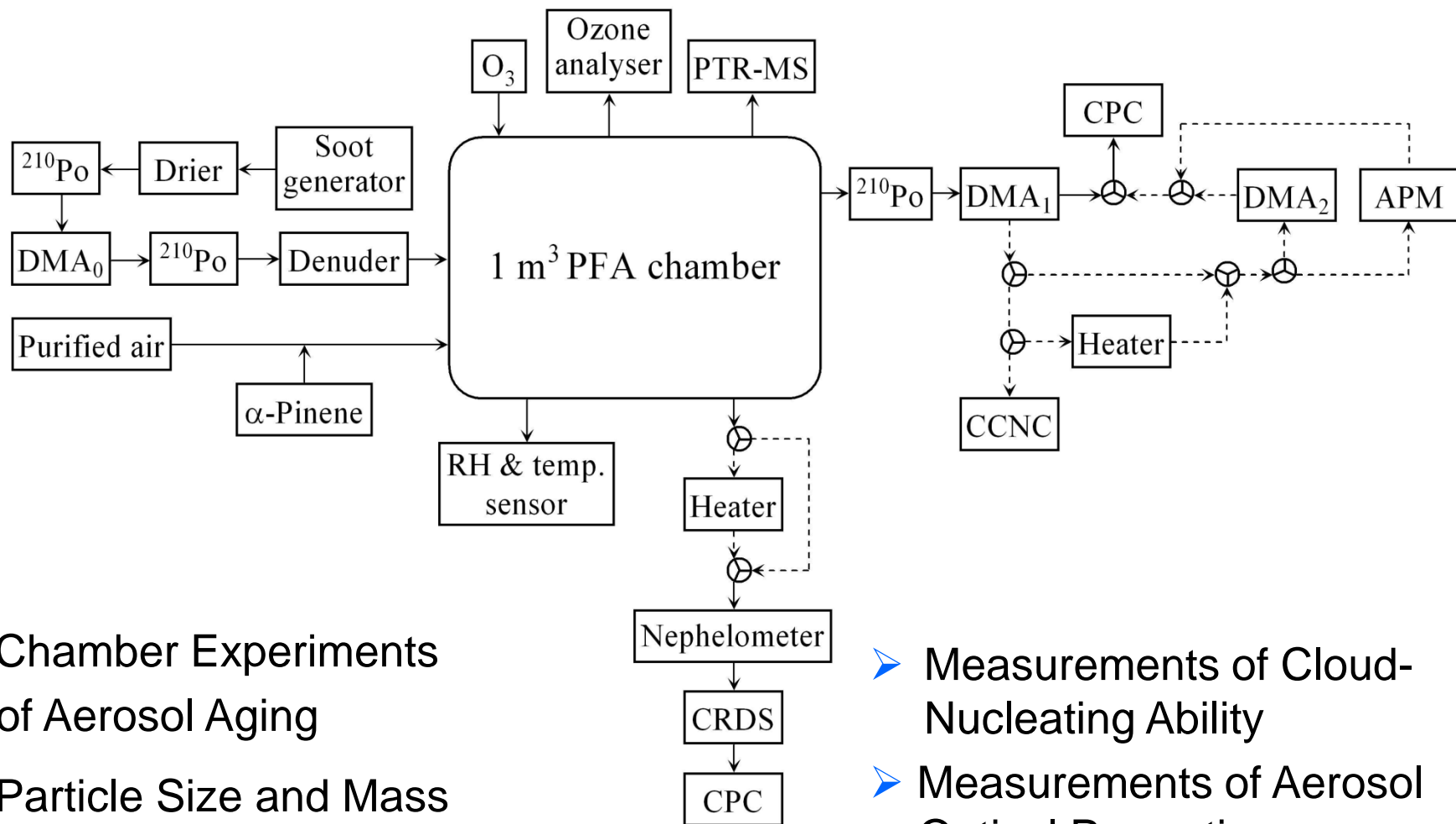

- Chamber Experiments of Aerosol Aging
- Particle Size and Mass Measurements
- Chemical Composition Analysis of Organic Material in the Soot Coating

- Measurements of Cloud-Nucleating Ability
- Measurements of Aerosol Optical Properties

TDMA-APM system

Operation modes:

- single DMA - CPC (SMPS)
- DMA - APM - CPC
- DMA - humidifier/heater - DMA - CPC (H/VTDMA)

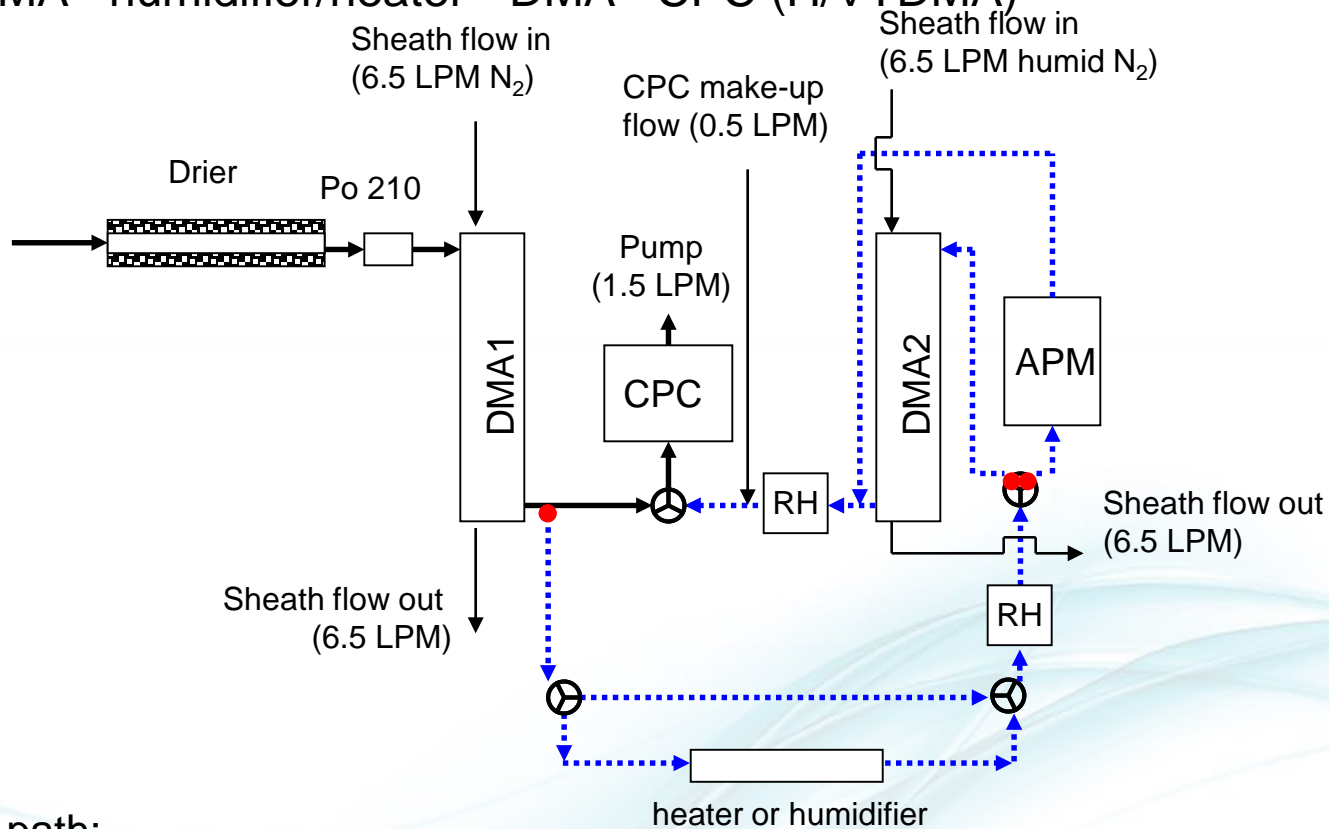

Aerosol path:

— DMA scan (size distribution)

..... TDMA or DMA-APM scan

Differential Mobility Analyzer (DMA)

Aerosol Particle Mass (APM) Analyzer

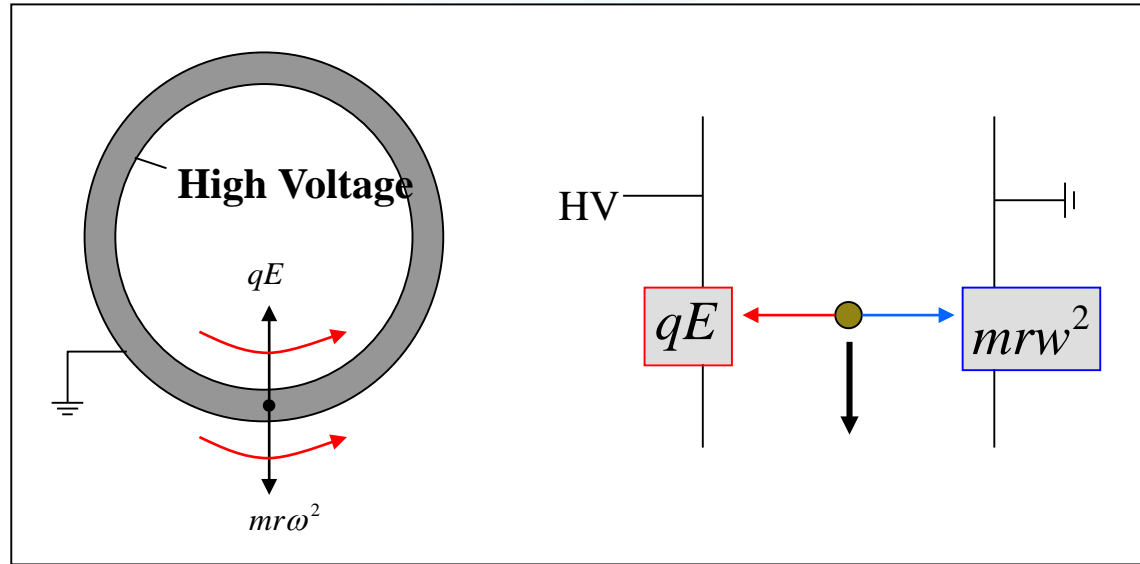
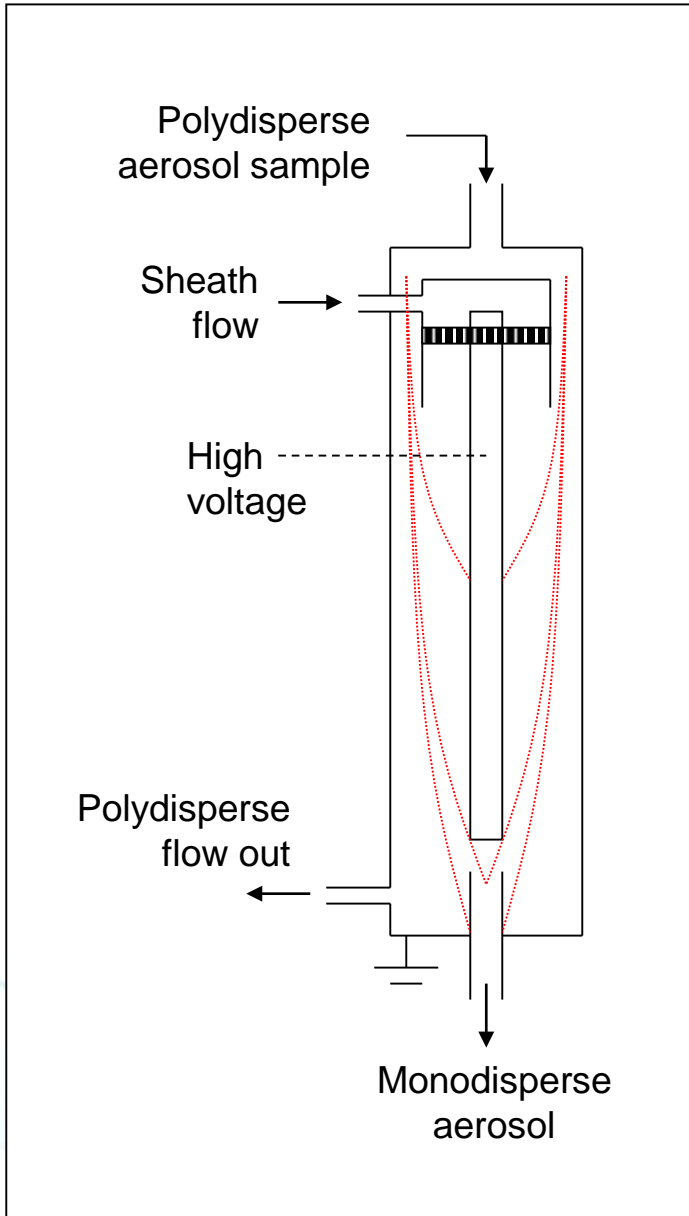

DMA

- Particles of a certain electrical mobility can penetrate through the DMA for the fixed sheath to sample flow ratio and voltage

$$Z_p = \frac{neC}{3\pi\mu D_p}$$

APM

- Particles of a certain mass can penetrate through the APM for the fixed rotational speed and voltage
- Electrostatic force = Centrifugal force

$$mr\omega^2 = \frac{\pi d_{ve}^3}{6} \rho_{true} r\omega^2 = neE_{APM}$$

Particle Effective Density, Mass Fractal Dimension and Dynamic shape factor

- Effective density, ρ_{eff} : calculated from the mass and mobility measurements

$$\rho_{\text{eff}} = \frac{m}{V} = \frac{6m}{d_B^3 \pi}$$

- Mass Fractal dimension, D_f : describing the compactness of the population of agglomerates constituting the aerosol (3.0 for spherical particles, 2.0 for a plane)

$$m \propto d_B^{D_{fm}}$$

- Dynamic shape factor, χ : a property solely determined by the particle morphology (1.0 for spherical particles)

$$\chi = \frac{d_B}{d_{ve}} \cdot \frac{C_{ve}}{C_B}$$

Size-resolved CCN Measurements

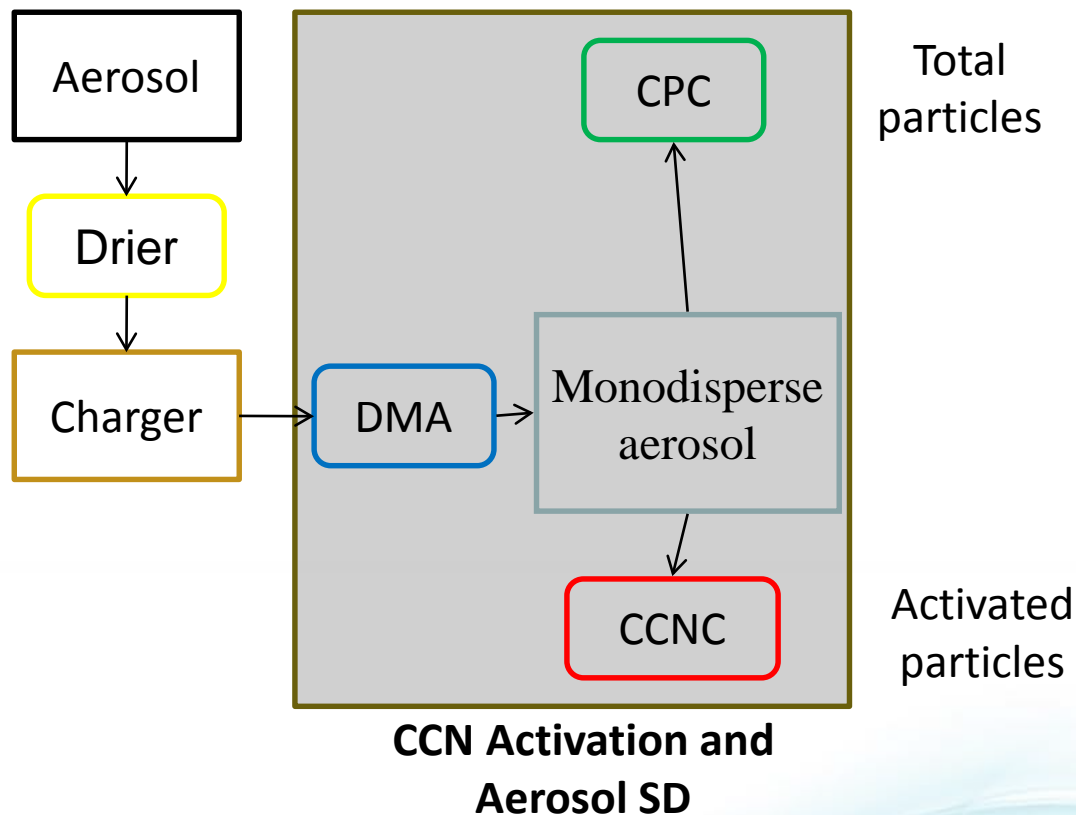

Activated particle fraction: CCN/CN ratio

Critical diameter: the size at which particles at a given supersaturation reach a CCN/CN ratio of 0.5

Single hygroscopicity parameter $\kappa = \frac{4A}{27d \ln^2 s}$, $A = \left(\frac{4M_w \sigma_w}{RT \rho_w} \right)^3$

Chemical Composition of Coated Particles: Ion Drift-Chemical Ionization Mass Spectrometry (CIMS)

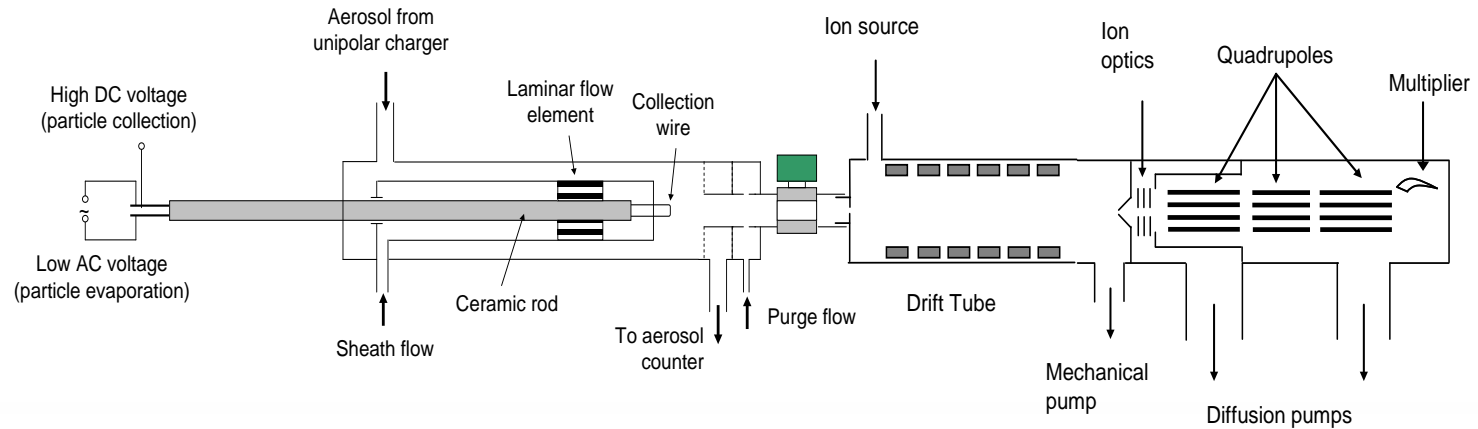

Typical size distribution: 30-100 nm

Charging efficiency: ~10%

Particle density: 1.0 g cm^{-3}

Flow rate: $1.0 \text{ liters min}^{-1}$

Collection time: 2.5 hours

Evolution of microphysical properties of soot

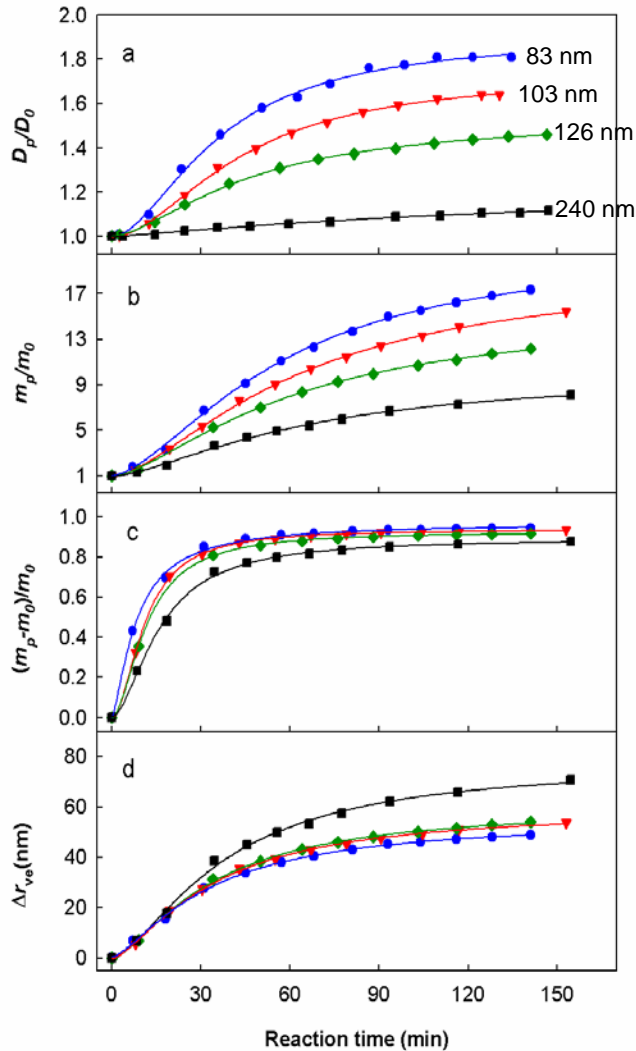

- D_p/D_0 : mobility diameter growth factor
- m_p/m_0 : mass growth factor
- $(m_p - m_o)/m_p$: organic mass fraction
- Volume equivalent coating thickness, Δr_{ve} : a measure for the amount of coating material deposited on the particle

➤ fast and large size and mass growth; smaller particles, larger growth factor

➤ particle organic mass fraction increased significantly, reaching ~80-90% within 30 min

initial concentrations of α -pinene ~37 ppb,
ozone ~ 20 ppb

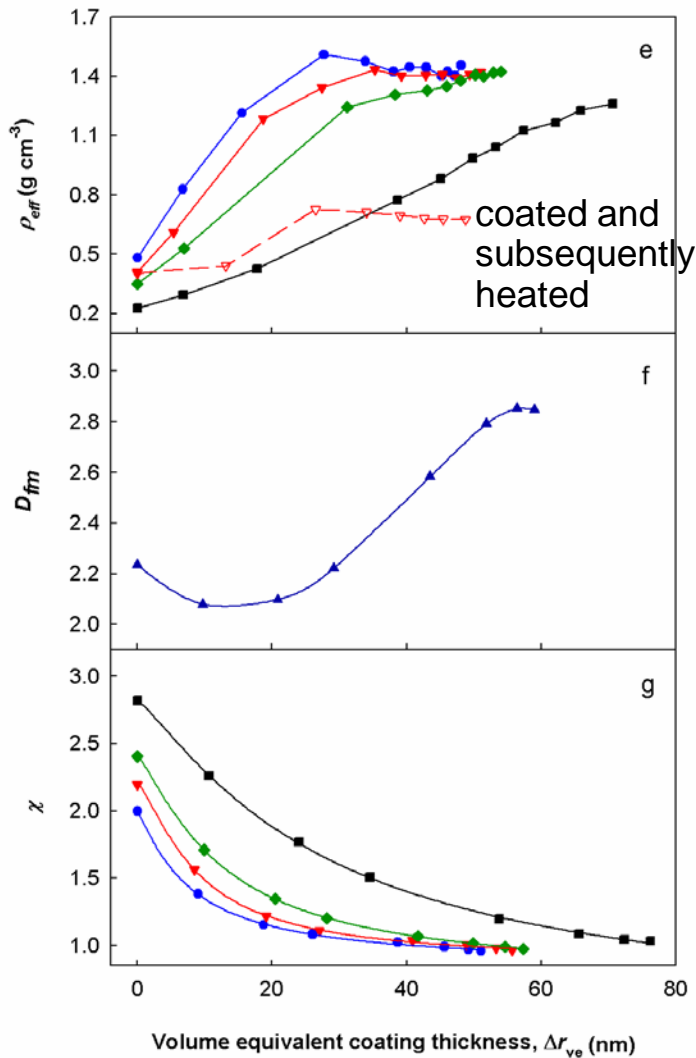

e, Particle effective density (ρ_{eff}) as a function of volume equivalent coating thickness (Δr_{ve}). Red open triangles denote effective density for coated and subsequently heated soot aggregates with a fresh diameter of 100 nm.

f, Particle mass fractal dimension (D_{fm}) as a function of volume equivalent coating thickness (Δr_{ve}).

g, Particle dynamic shape factor (χ) as a function of volume equivalent coating thickness (Δr_{ve}).

- marked changes in particle morphology: transformed to more compact and dense spherical particles
- restructuring of the soot core to a more compact form during the initial stages of coating

CCN activity of soot upon coating

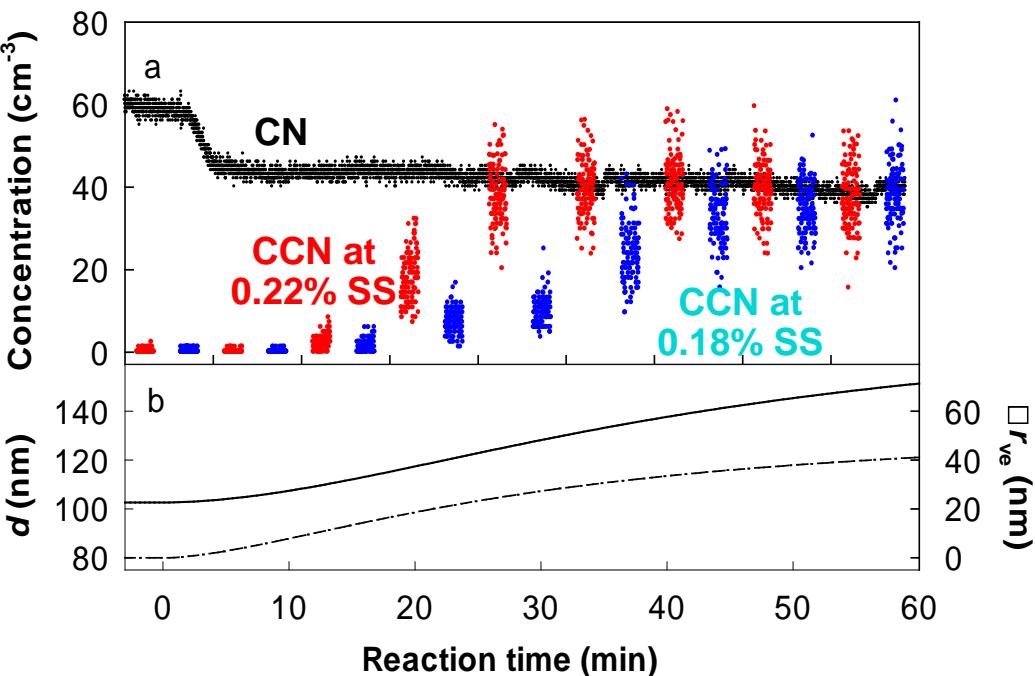

➤ At 0.22% and 0.18% supersaturation, particles begin to activate in ~10 and 15 min, respectively, and full CCN activation was achieved at ~30 and 60 min, respectively

a. Time evolution soot particles with the soot particles with an initial mobility diameter of 103 nm, exposed to 37 ppb α -pinene and 20 ppb ozone. b, Time evolution of particle volume equivalent diameter.

Chemical composition of the organic material in coated soot

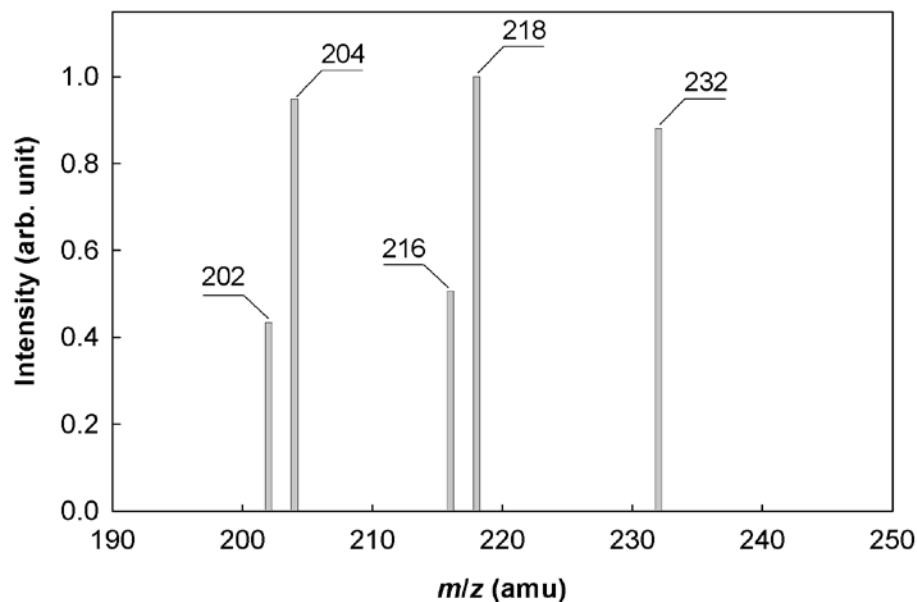

➤ Pinic acid, norpinic acid, and hydroxy-pinonic acid were identified as the most abundant organic acids in the soot coating, consistent with their low volatility.

Mass-charge ratios (m/z) of 202, 204, 216, 218, and 232 correspond to the ion-molecule reaction products of pinalic acid, norpinic acid, pinonic acid, pinic acid and hydroxy-pinonic acid, respectively.

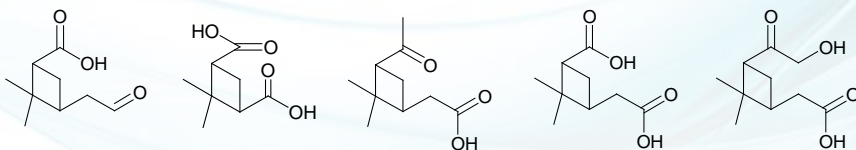

Timescale for CCN activation

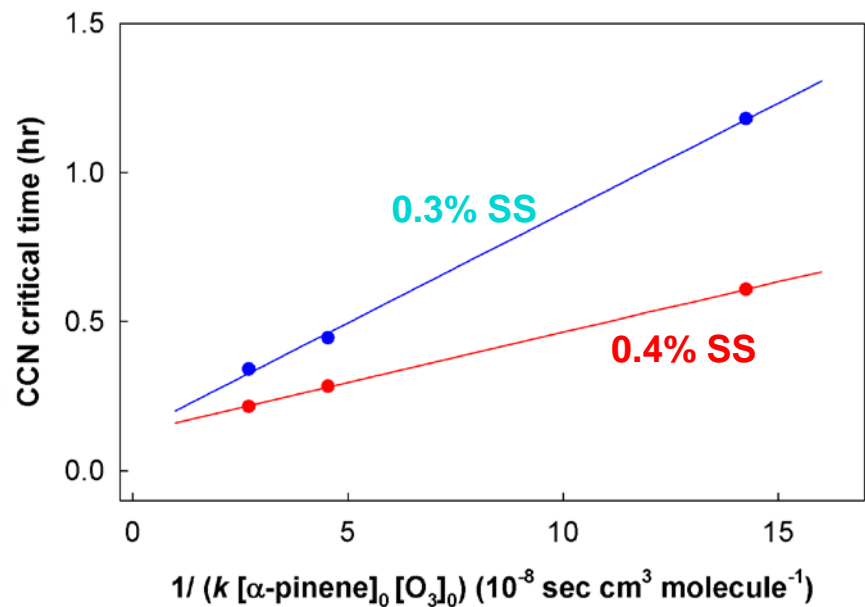

Correlation plot of coated soot CCN critical time with initial reaction concentrations

➤ By extrapolating to ambient conditions of 1 ppb α -pinene, and 30 ppb O_3 , the CCN critical time ~ 2.4 hr at 0.4 % supersaturation, ~ 5.0 hr at 0.3 % supersaturation, in contrast to assumed aging time of more than 1 day for the evolution of hydrophobic black carbon into hydrophilic CCN in global models.

Summary of critical supersaturations for coated soot particles

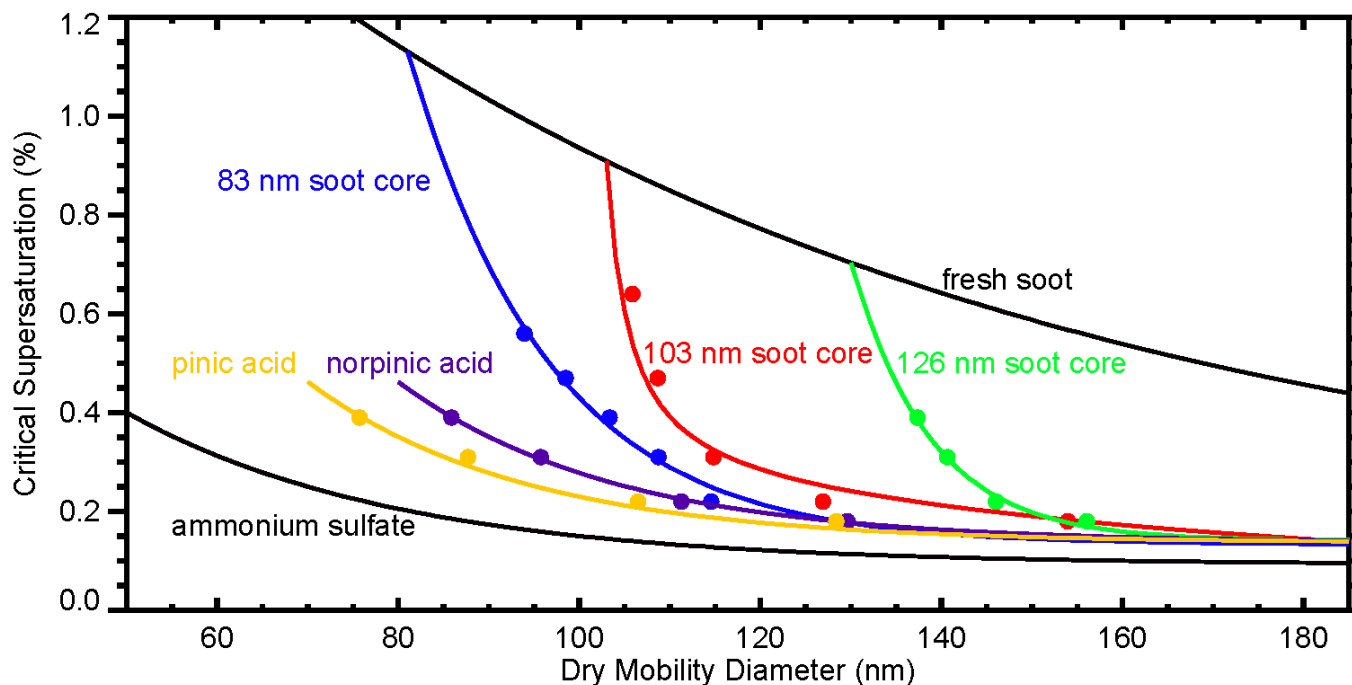

- CCN activation dependent on both the coating and initial core size of primary particles during the initial stages of aging.
- For sufficiently coated primary particles, the CCN activity is largely determined by coating formed during their atmospheric aging, regardless of the composition or size of the original primary particles.

The background of the slide features a light blue and white color scheme with soft, flowing, wavy lines that create a sense of movement and depth. The lines are more prominent at the top and bottom edges, framing the central text.

Field experiments

Air monitoring supersite



Online measurements of atmospheric aerosols and precursor gases

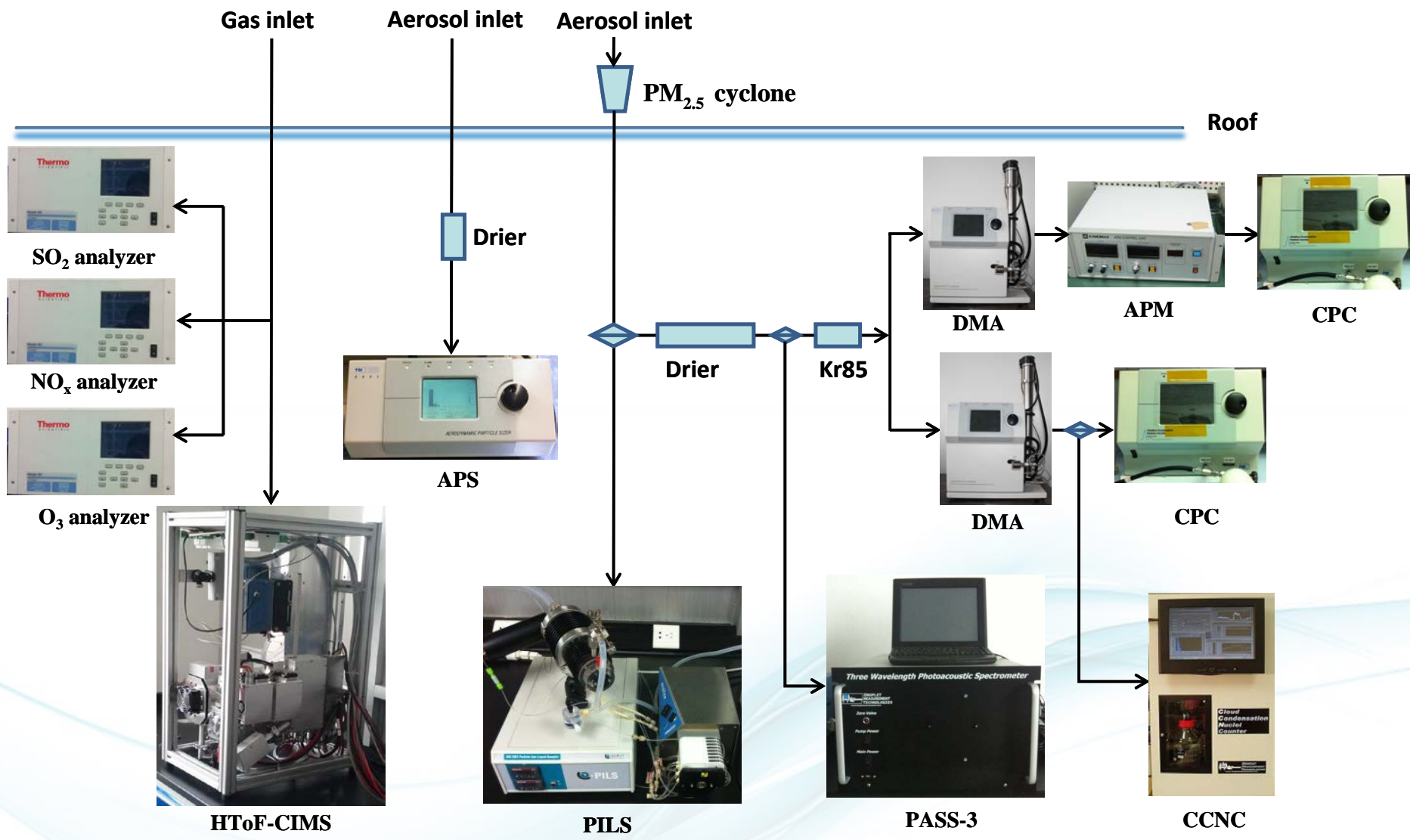

Field measurements

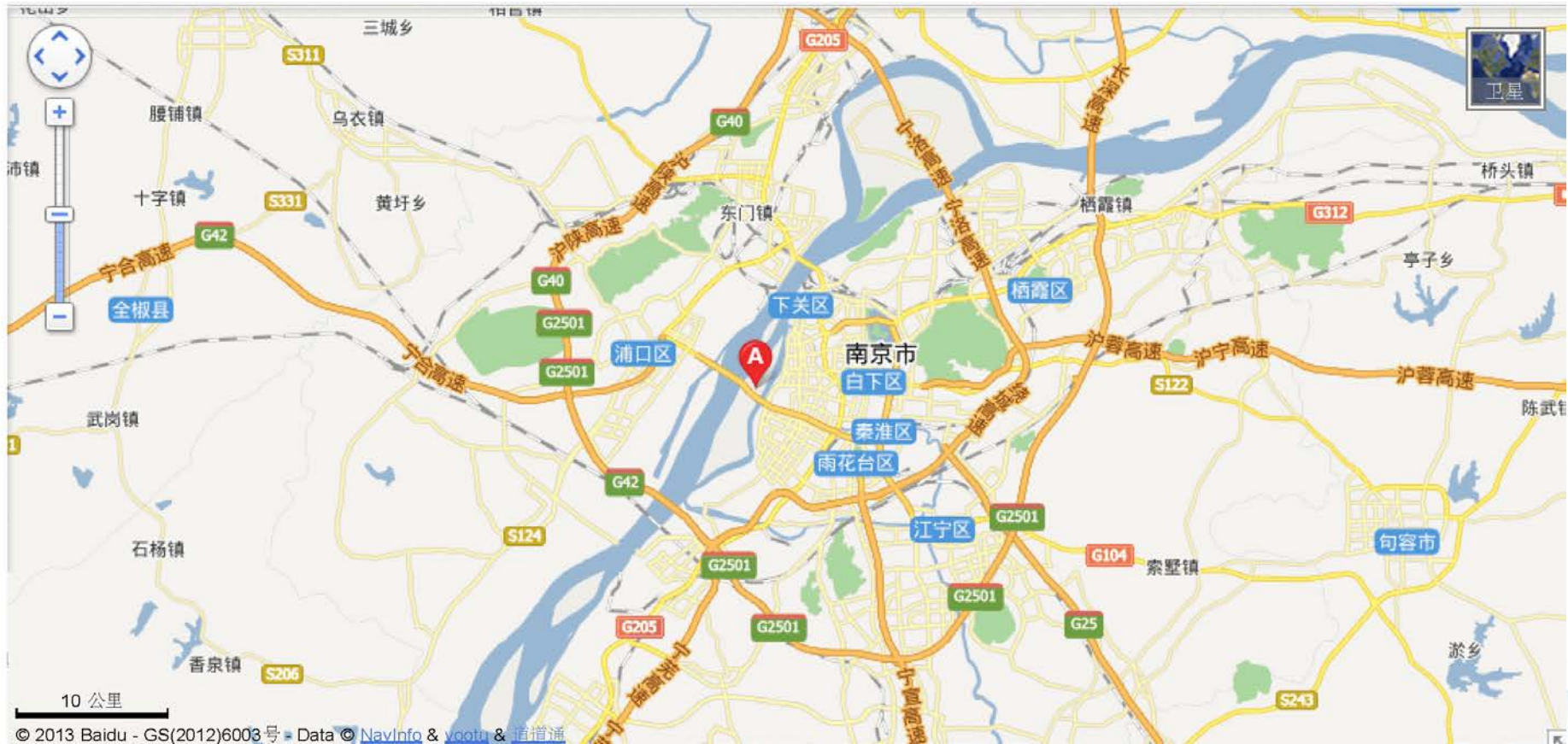

**A: Nanjing Bureau of Meteorology,
Nanjing
Summer of 2013 & 2014**

Aerosol mixing state

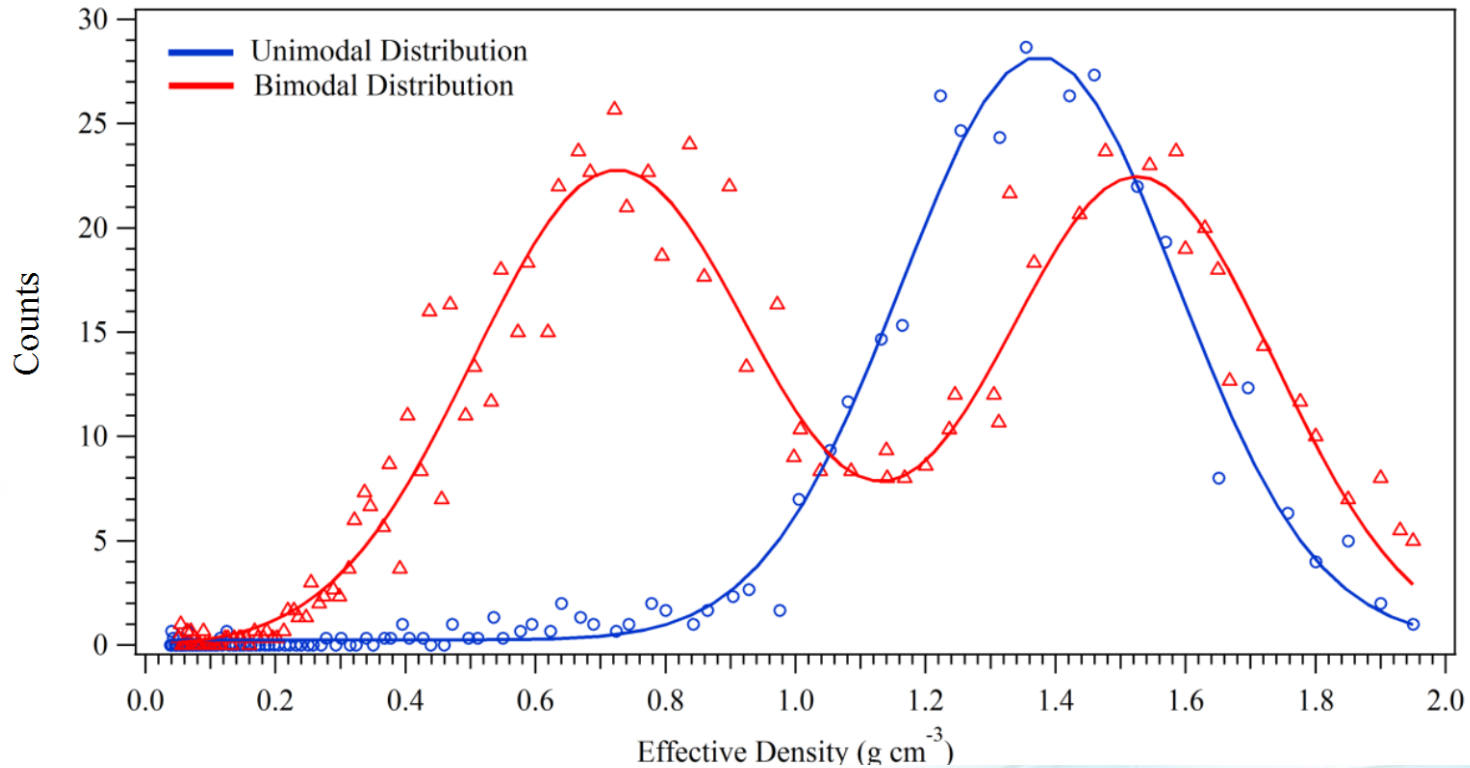

- Aerosols at the observation site were mostly internally mixed
- Externally mixed BC was only occasionally observed with an effective density of 0.5–0.9 g cm⁻³

Size-resolved effective density

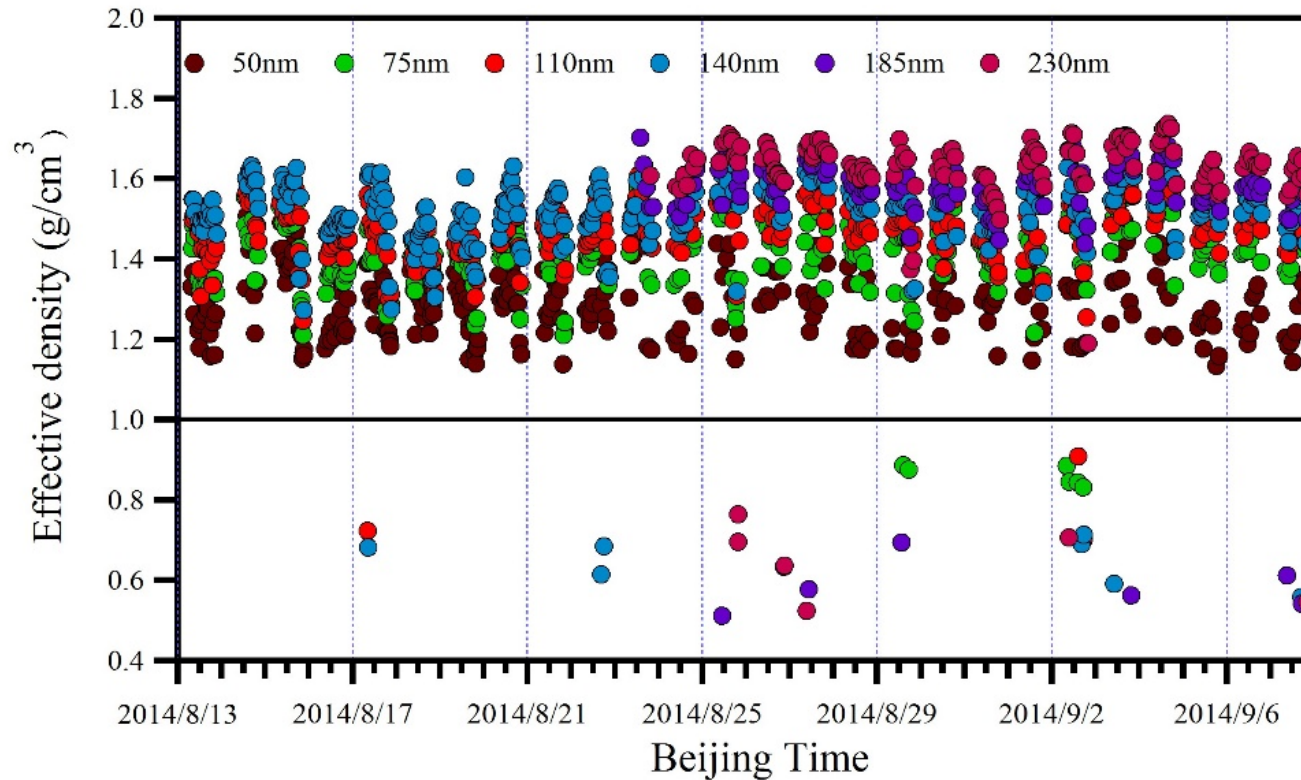

- Aerosol density averaged 1.30-1.63 g cm⁻³ for 50-230 nm particles, increasing with particle size.

Mass and number fraction of BC

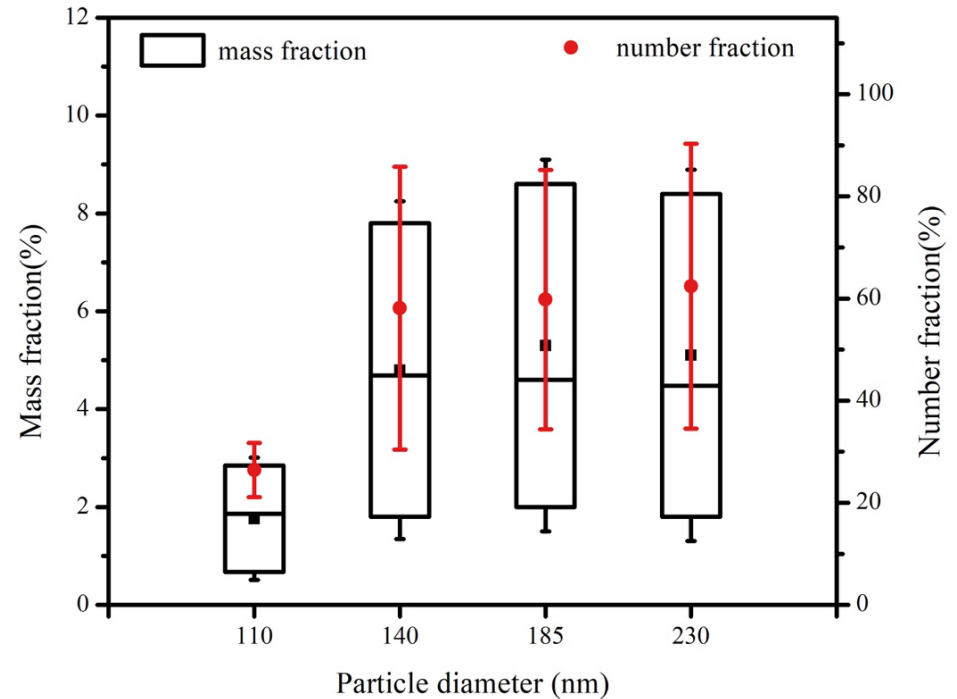
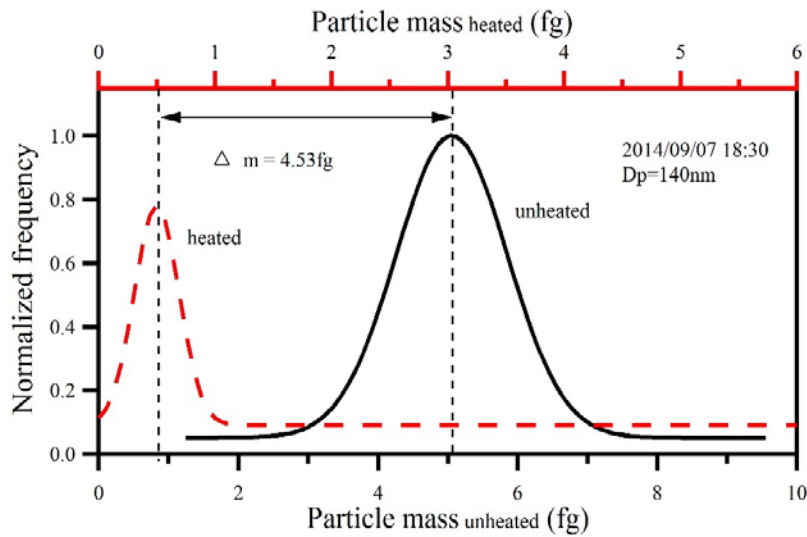

- BC accounted for only minor fraction of the particle mass but was present in a significant fraction of particle number concentration

Cloud-nucleating properties

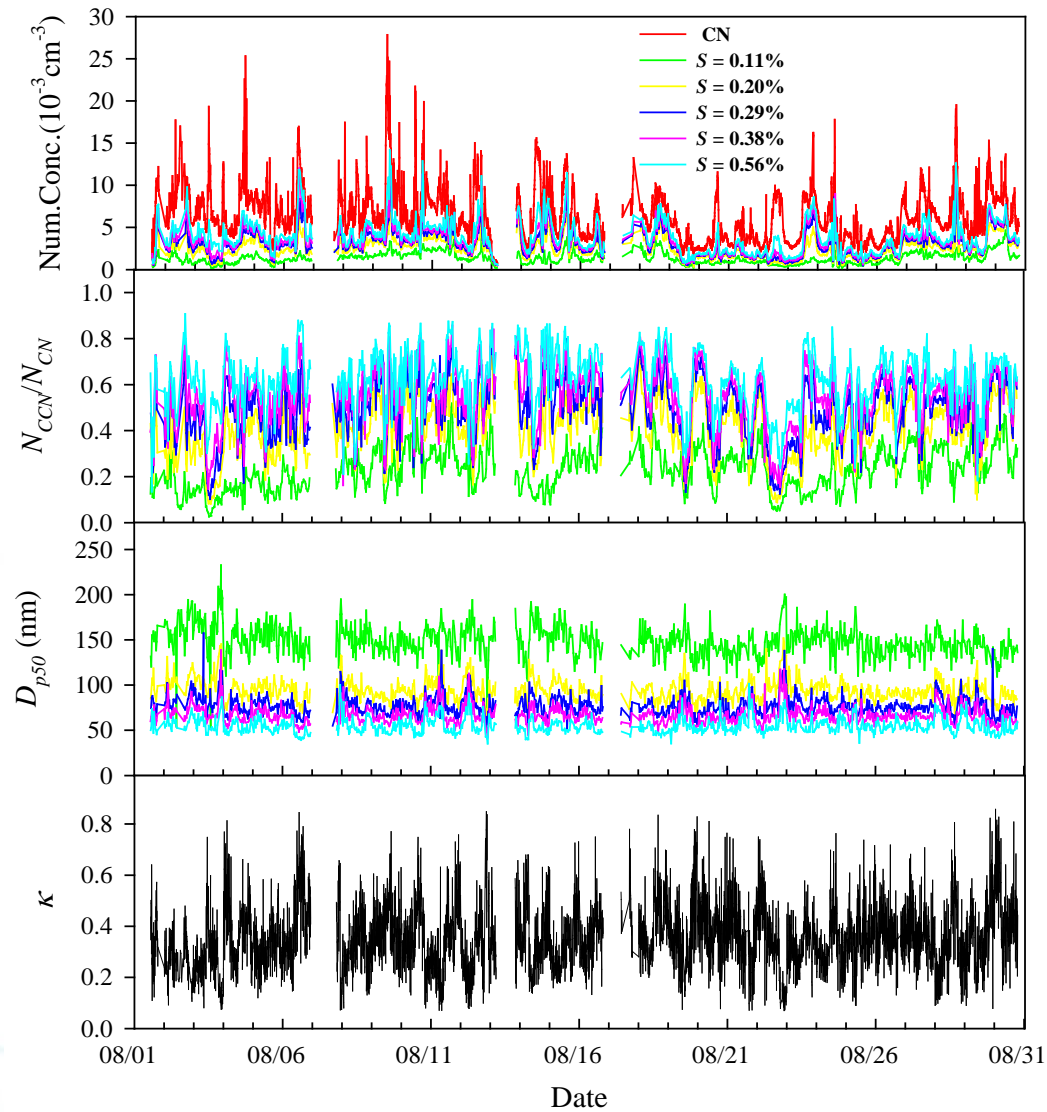

➤ Average $\kappa \sim 0.35 \pm 0.13$, higher than proposed continental average of 0.3

Effect of atmospheric aging

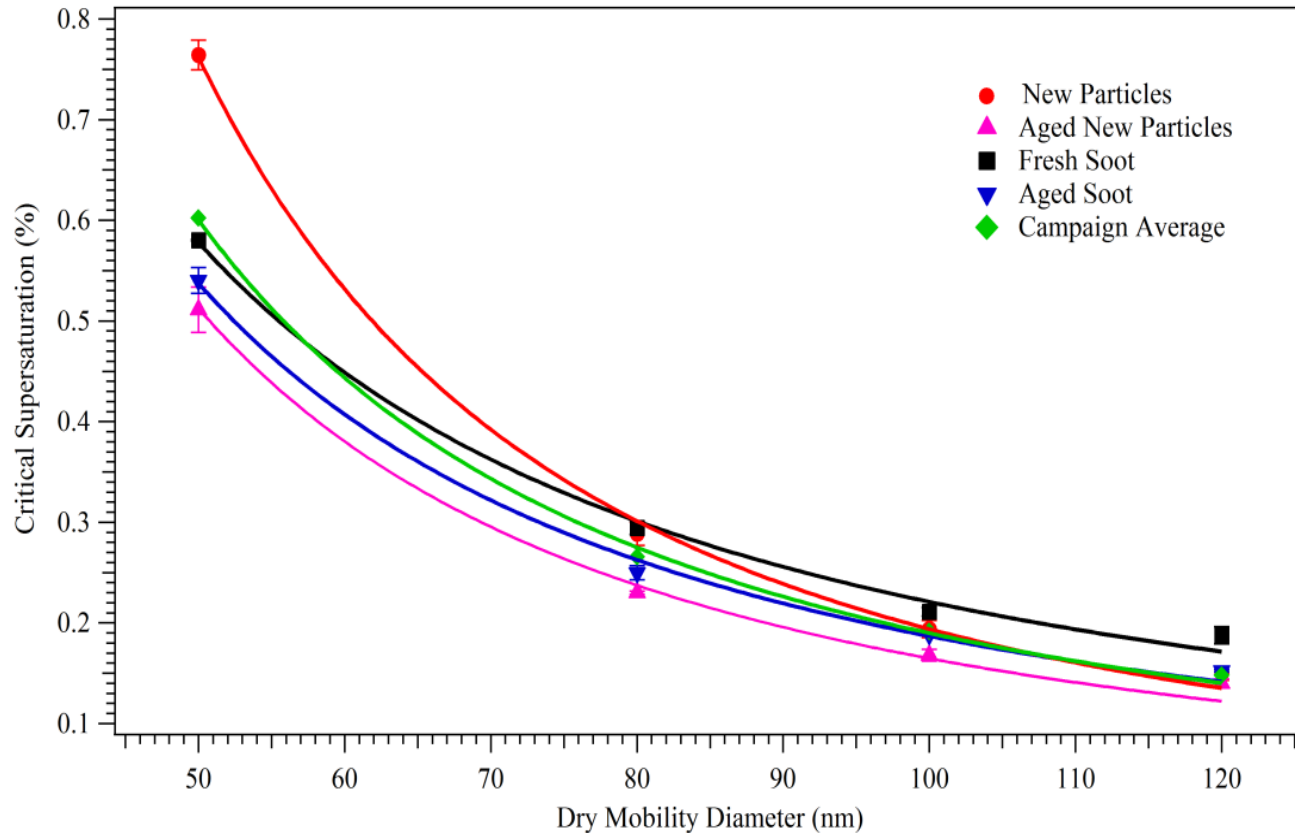

- Both newly formed particles and freshly emitted BC particles aged rapidly from photochemical processes, with a significant enhancement in the particle CCN activity and an increase in the effective density.

CCN activation for different periods representing different air masses

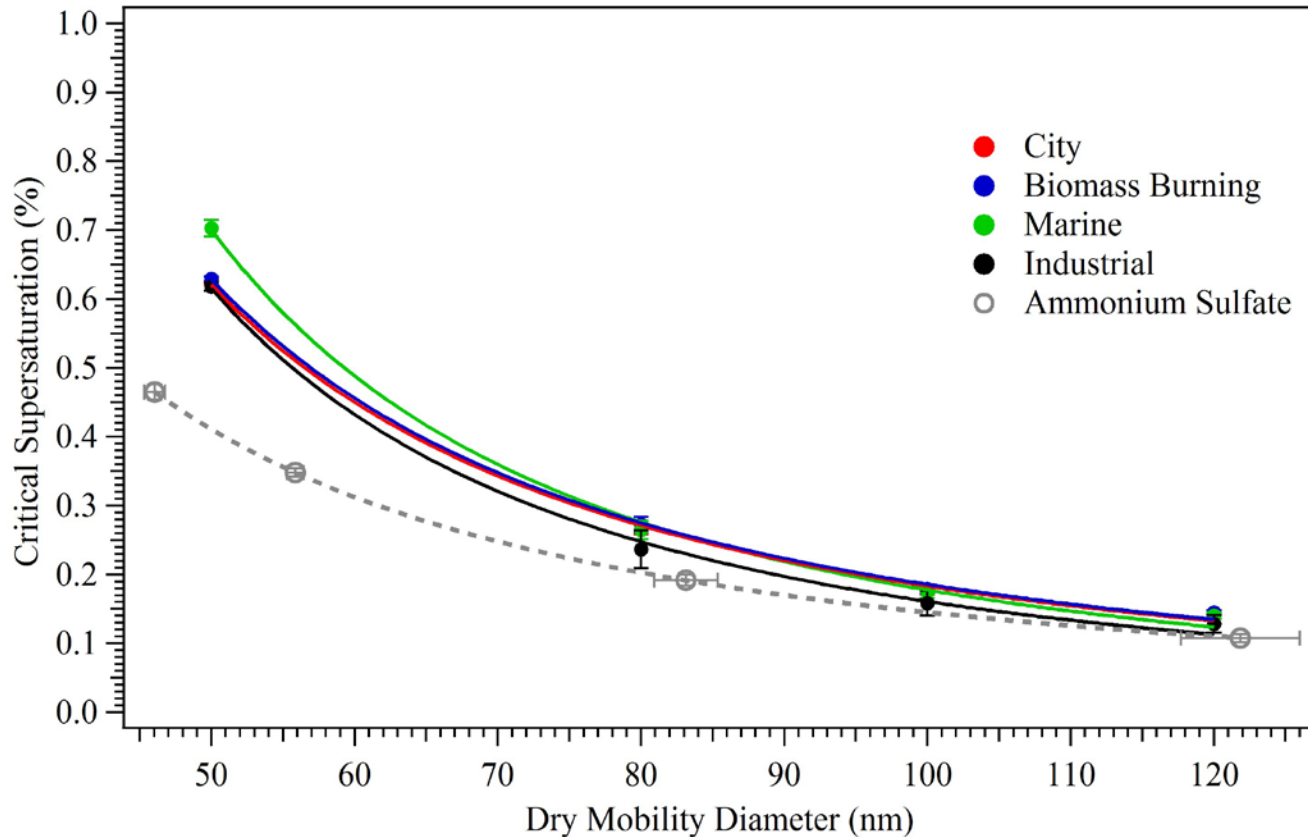

- Aerosols influenced by four different air masses presented similar CCN activation, indicating that CCN activation would be primarily dependent on the particle size rather than the particle origin (and hence original composition).

CCN closure studies assuming external or internal mixture

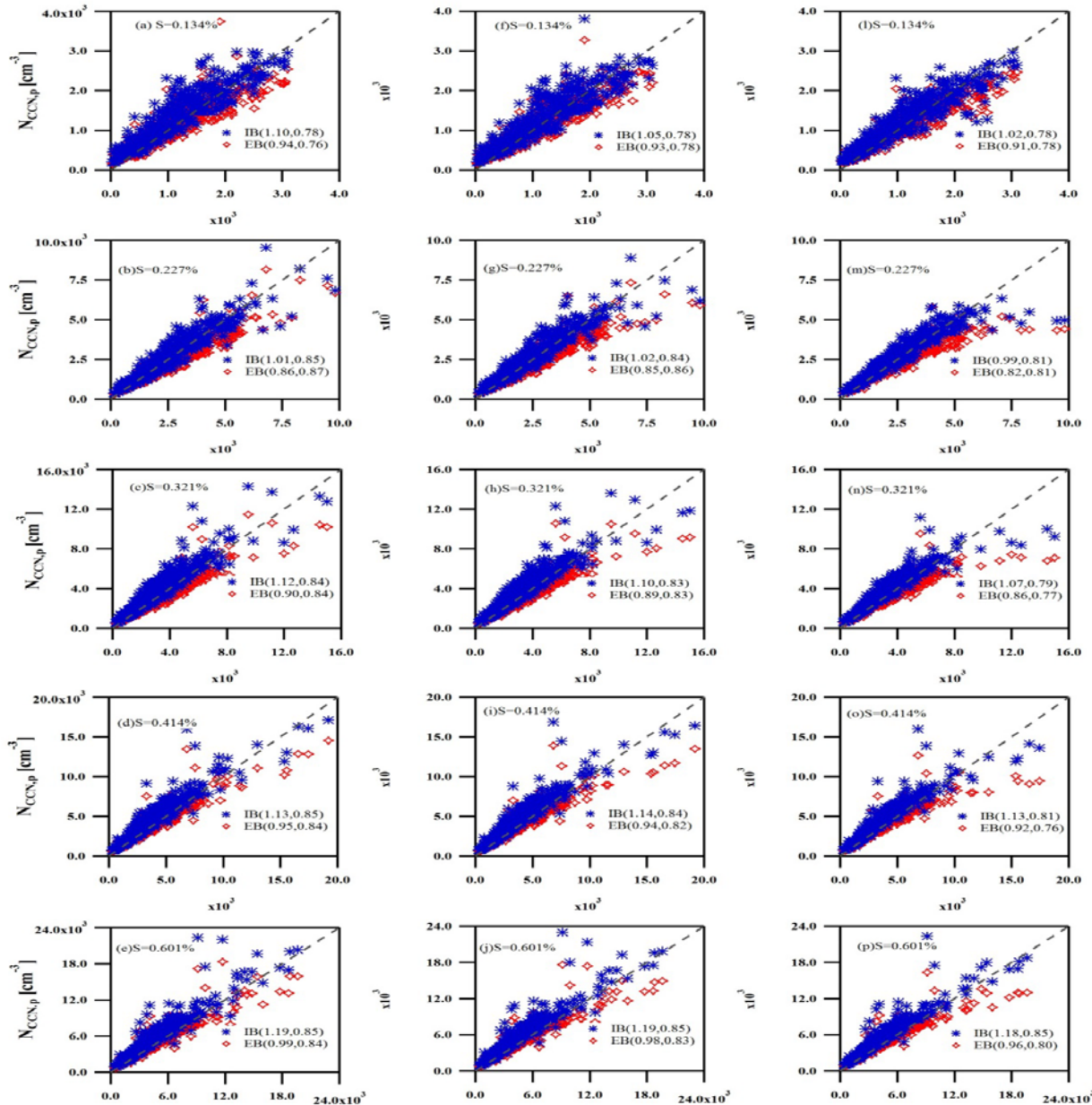

➤ CCN closure study assuming **internal mixture (IB)** generates better results at lower supersaturations; while that assuming **external mixture (EB)** gives better closure at higher supersaturations.

➤ Increasing time resolution of chemical composition data slightly improves closure results.

Improved method assuming internal mixture with E (size-resolved fraction of CCN-active particles)

S(%)	EB	IB	IBE
0.134	0.95 (0.77)	1.03 (0.78)	1.06 (0.77)
0.227	0.85 (0.84)	1.01 (0.84)	1.00 (0.83)
0.321	0.87 (0.81)	1.09 (0.82)	1.05 (0.80)
0.414	0.89 (0.79)	1.13 (0.83)	1.07 (0.81)
0.601	0.90 (0.81)	1.19 (0.85)	1.08 (0.82)
Average	0.89 (0.87)	1.13 (0.89)	1.06 (0.87)

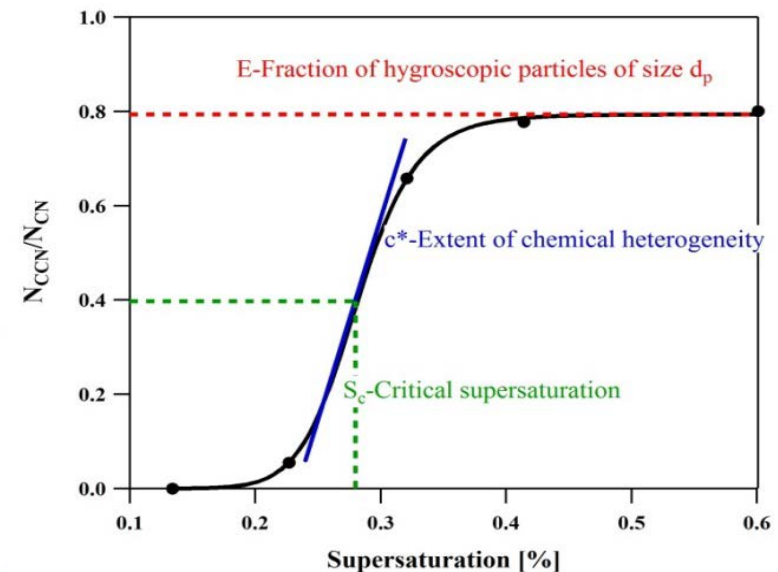

- Including size-resolved E (derived from size-resolved CCN measurement) can correct the overestimation by assuming entirely internal mixture, and the underestimation by assuming external mixture.

Conclusions

- Fast transformation of primary aerosols occurs during atmospheric aging.
- Ambient aerosols observed in the campaign are predominantly internally mixed.
- For sufficiently aged particles, the CCN activity is largely determined by coating formed during their atmospheric aging, regardless of the origin or composition of the original particles.
- Mixing state plays a role in prediction of CCN number concentrations. The method including E (size-resolved fraction of CCN active particles) can improve closure results.

The background features light blue, wavy, translucent lines that flow across the top and bottom of the slide, creating a sense of movement and depth. The central text is a bold, blue, sans-serif font with a subtle reflection effect below it.

Thanks for your attention!