

An online model for air-sea exchange of mercury:  
insights for the influence of atmospheric  
deposition on ocean concentrations

Yanxu Zhang

School of Atmospheric Sciences,  
Nanjing University

05/22/2018 NUIST

# Mercury as an element

## PERIODIC TABLE OF THE ELEMENTS

<http://www.ktf-split.hr/periodni/en/>

PERIOD	GROUP	1	2	3	4	5	6	7	8	9	10	11	12	13	14	15	16	17	18	
		IA	IIA	III B										IIIA	IVA	VA	VIA	VIIA	VIIIA	
1		1 1.0079 <b>H</b> HYDROGEN																		2 4.0026 <b>He</b> HELIUM
2		3 6.941 <b>Li</b> LITHIUM	4 9.0122 <b>Be</b> BERYLLIUM											5 10.811 <b>B</b> BORON	6 12.011 <b>C</b> CARBON	7 14.007 <b>N</b> NITROGEN	8 15.999 <b>O</b> OXYGEN	9 18.998 <b>F</b> FLUORINE	10 20.180 <b>Ne</b> NEON	
3		11 22.990 <b>Na</b> SODIUM	12 24.305 <b>Mg</b> MAGNESIUM											13 26.982 <b>Al</b> ALUMINIUM	14 28.086 <b>Si</b> SILICON	15 30.974 <b>P</b> PHOSPHORUS	16 32.065 <b>S</b> SULPHUR	17 35.453 <b>Cl</b> CHLORINE	18 39.948 <b>Ar</b> ARGON	
4		19 39.098 <b>K</b> POTASSIUM	20 40.078 <b>Ca</b> CALCIUM	21 44.956 <b>Sc</b> SCANDIUM	22 47.867 <b>Ti</b> TITANIUM	23 50.942 <b>V</b> VANADIUM	24 51.996 <b>Cr</b> CHROMIUM	25 54.938 <b>Mn</b> MANGANESE	26 55.845 <b>Fe</b> IRON	27 58.933 <b>Co</b> COBALT	28 58.693 <b>Ni</b> NICKEL	29 63.546 <b>Cu</b> COPPER	30 65.39 <b>Zn</b> ZINC	31 69.723 <b>Ga</b> GALLIUM	32 72.64 <b>Ge</b> GERMANIUM	33 74.922 <b>As</b> ARSENIC	34 78.96 <b>Se</b> SELENIUM	35 79.904 <b>Br</b> BROMINE	36 83.80 <b>Kr</b> KRYPTON	
5		37 85.468 <b>Rb</b> RUBIDIUM	38 87.62 <b>Sr</b> STRONTIUM	39 88.906 <b>Y</b> YTTRIUM	40 91.224 <b>Zr</b> ZIRCONIUM	41 92.906 <b>Nb</b> NIOBIUM	42 95.94 <b>Mo</b> MOLYBDENUM	43 (98) <b>Tc</b> TECHNETIUM	44 101.07 <b>Ru</b> RUTHENIUM	45 102.91 <b>Rh</b> RHODIUM	46 106.42 <b>Pd</b> PALLADIUM	47 107.87 <b>Ag</b> SILVER	48 112.41 <b>Cd</b> CADMIUM	49 114.82 <b>In</b> INDIUM	50 118.71 <b>Sn</b> TIN	51 121.76 <b>Sb</b> ANTIMONY	52 127.60 <b>Te</b> TELLURIUM	53 126.90 <b>I</b> IODINE	54 131.29 <b>Xe</b> XENON	
6		55 132.91 <b>Cs</b> CAESIUM	56 137.33 <b>Ba</b> BARIUM	57-71 <b>La-Lu</b> Lanthanide	72 178.49 <b>Hf</b> HAFNIUM	73 180.95 <b>Ta</b> TANTALUM	74 183.84 <b>W</b> TUNGSTEN	75 186.21 <b>Re</b> RHENIUM	76 190.23 <b>Os</b> OSMIUM	77 192.22 <b>Ir</b> IRIDIUM	78 195.08 <b>Pt</b> PLATINUM	79 196.97 <b>Au</b> GOLD	80 200.59 <b>Hg</b> MERCURY	81 204.38 <b>Tl</b> THALLIUM	82 207.2 <b>Pb</b> LEAD	83 208.98 <b>Bi</b> BISMUTH	84 (209) <b>Po</b> POLONIUM	85 (210) <b>At</b> ASTATINE	86 (222) <b>Rn</b> RADON	
7		87 (223) <b>Fr</b> FRANCIUM	88 (226) <b>Ra</b> RADIUM	89-103 <b>Ac-Lr</b> Actinide	104 (261) <b>Rf</b> RUTHERFORDIUM	105 (262) <b>Db</b> DUBNIUM	106 (266) <b>Sg</b> SEABORGIUM	107 (264) <b>Bh</b> BOHRIUM	108 (277) <b>Hs</b> HASSIUM	109 (268) <b>Mt</b> MEITNERIUM	110 (281) <b>Uun</b> UNUNNIUM	111 (272) <b>Uuu</b> UNUNUNIUM	112 (285) <b>Uub</b> UNUBIUM		114 (289) <b>Uuq</b> UNUNQUADIUM					

### LANTHANIDE

57 138.91 <b>La</b> LANTHANUM	58 140.12 <b>Ce</b> CERIUM	59 140.91 <b>Pr</b> PRASEODYMIUM	60 144.24 <b>Nd</b> NEODYMIUM	61 (145) <b>Pm</b> PROMETHIUM	62 150.36 <b>Sm</b> SAMARIUM	63 151.96 <b>Eu</b> EUROPIUM	64 157.25 <b>Gd</b> GADOLINIUM	65 158.93 <b>Tb</b> TERBIUM	66 162.50 <b>Dy</b> DYSPROSIUM	67 164.93 <b>Ho</b> HOLMIUM	68 167.26 <b>Er</b> ERBIUM	69 168.93 <b>Tm</b> THULIUM	70 173.04 <b>Yb</b> YTTERIUM	71 174.97 <b>Lu</b> LUTETIUM
-------------------------------------	----------------------------------	--	-------------------------------------	-------------------------------------	------------------------------------	------------------------------------	--------------------------------------	-----------------------------------	--------------------------------------	-----------------------------------	----------------------------------	-----------------------------------	------------------------------------	------------------------------------

### ACTINIDE

89 (227) <b>Ac</b> ACTINIUM	90 232.04 <b>Th</b> THORIUM	91 231.04 <b>Pa</b> PROTACTINIUM	92 238.03 <b>U</b> URANIUM	93 (237) <b>Np</b> NEPTUNIUM	94 (244) <b>Pu</b> PLUTONIUM	95 (243) <b>Am</b> AMERICIUM	96 (247) <b>Cm</b> CURIUM	97 (247) <b>Bk</b> BERKELIUM	98 (251) <b>Cf</b> CALIFORNIUM	99 (252) <b>Es</b> EINSTEINIUM	100 (257) <b>Fm</b> FERMIUM	101 (258) <b>Md</b> MENDELEVIUM	102 (259) <b>No</b> NOBELIUM	103 (262) <b>Lr</b> LAWRENCIUM
-----------------------------------	-----------------------------------	--	----------------------------------	------------------------------------	------------------------------------	------------------------------------	---------------------------------	------------------------------------	--------------------------------------	--------------------------------------	-----------------------------------	---------------------------------------	------------------------------------	--------------------------------------

(1) Pure Appl. Chem., 73, No. 4, 667-683 (2001)  
Relative atomic mass is shown with five significant figures. For elements having no stable nuclides, the value enclosed in brackets indicates the mass number of the longest-lived isotope of the element.

However three such elements (Th, Pa, and U) do have a characteristic terrestrial isotopic composition, and for these an atomic weight is tabulated.

Editor: Aditya Vardhan (advvar@netlinx.com)

The only metal that is liquid at standard state, vapor as a noble gas in air

# Mercury as a Neurotoxin

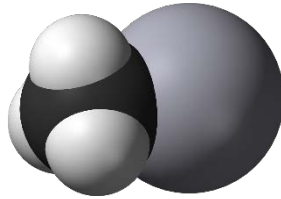

Dietary exposure: fish and seafood

## Minamata Convention on mercury

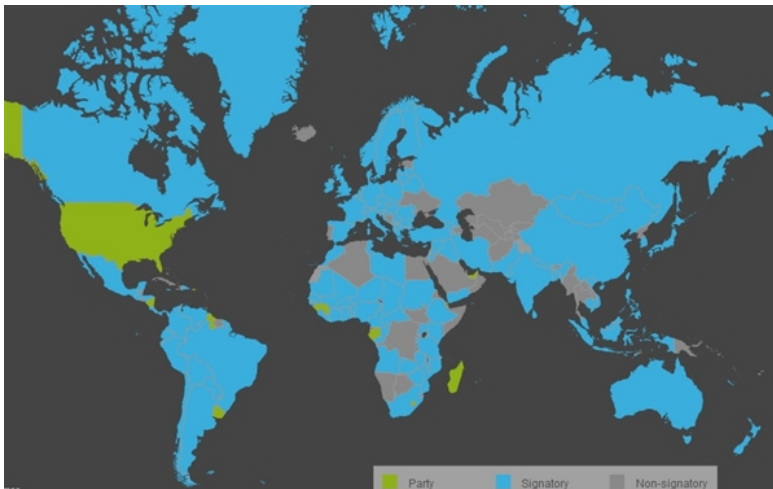

- Requires best available technology for coal-fired power plants
- Mercury mining to be banned in 15 years
- Regulation of mercury use in artisanal gold mining

**A Key challenge: quantify land/ocean re-emissions**

# Importance of air-sea exchange in global mercury cycle

## Biggest reservoir for Hg

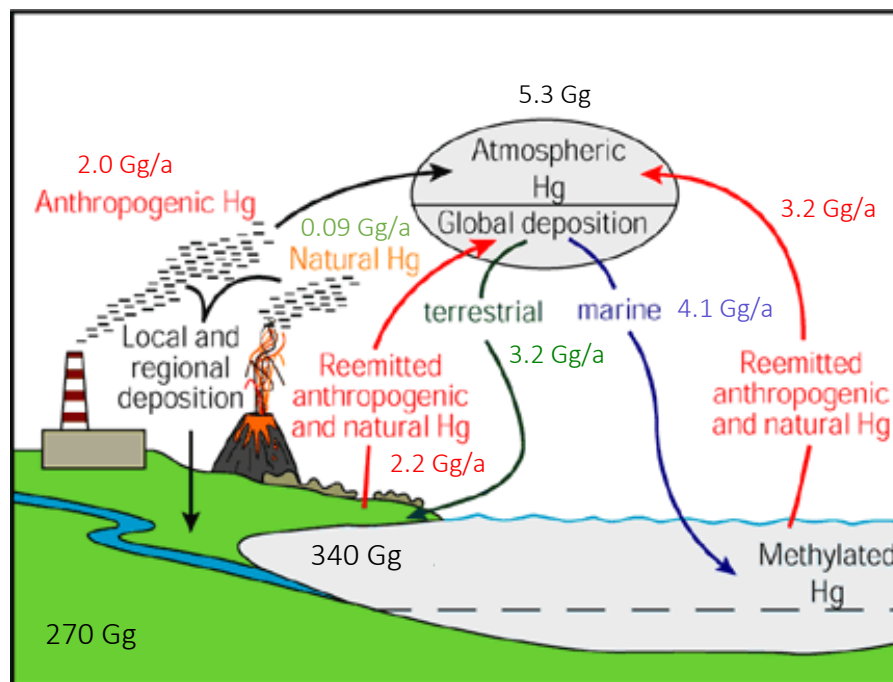

Holmes et al., 2010

### Key questions so far:

1. Lack of observations
2. Flux highly uncertain
3. Driving factors/seasonal cycle unclear

# Impact factors for air-sea exchange of mercury

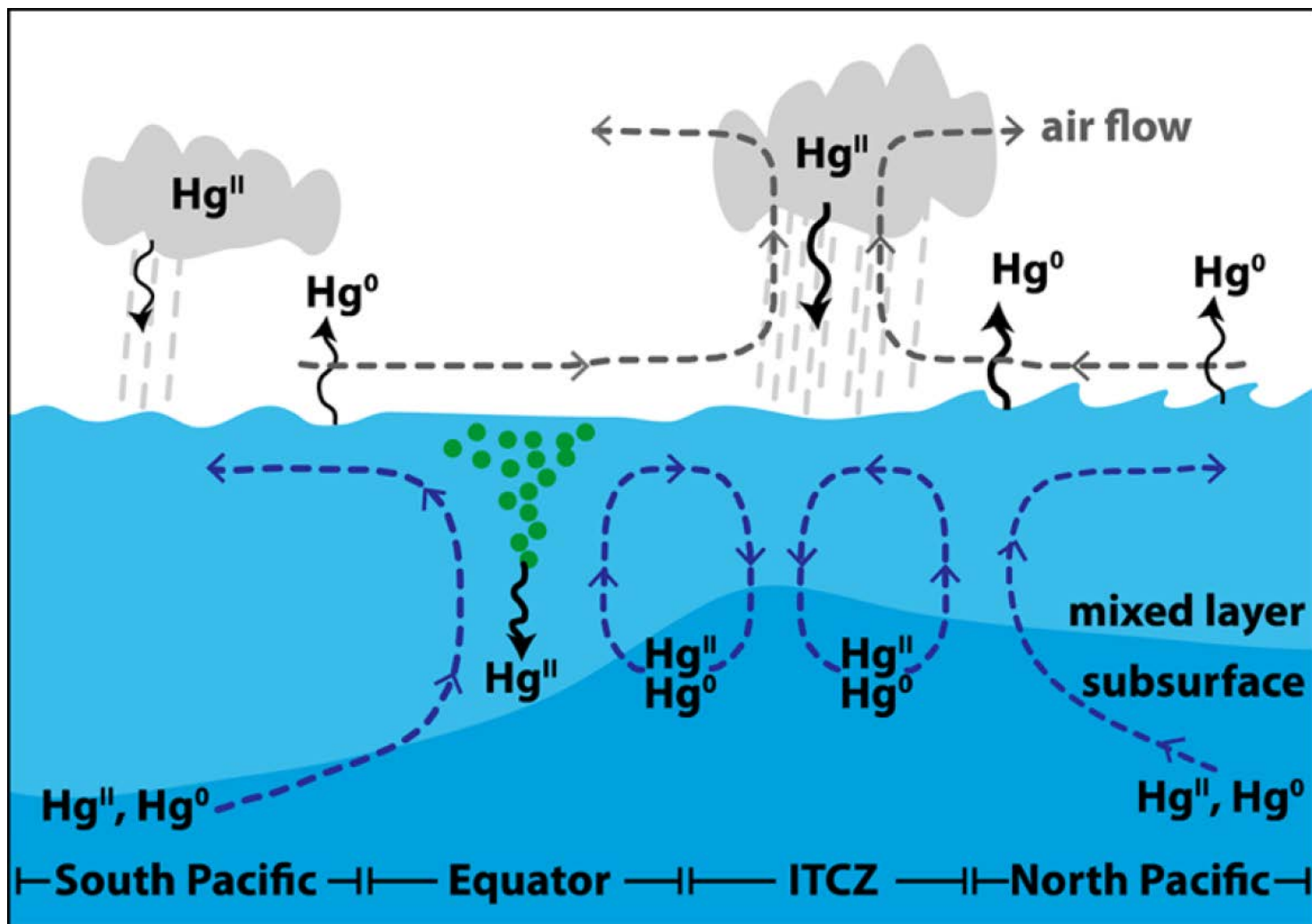

# A brief history of air-sea exchange models

2-box model

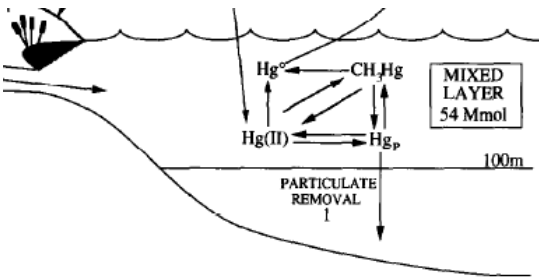

14-box model

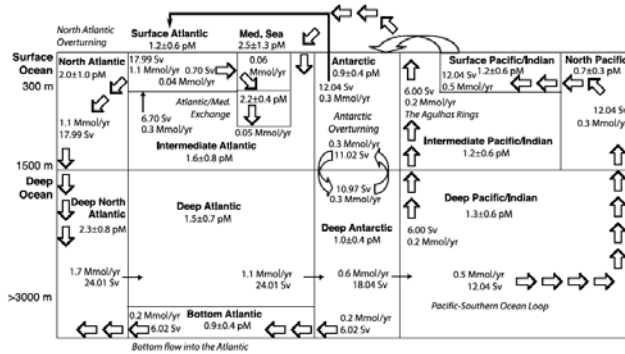

3d offline model

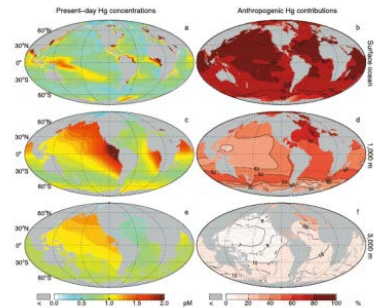

3-box model

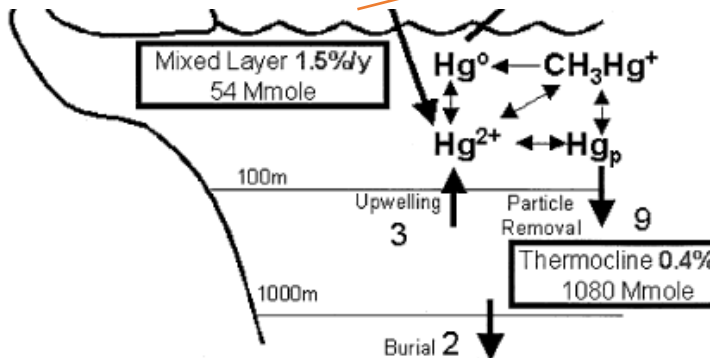

2d slab model

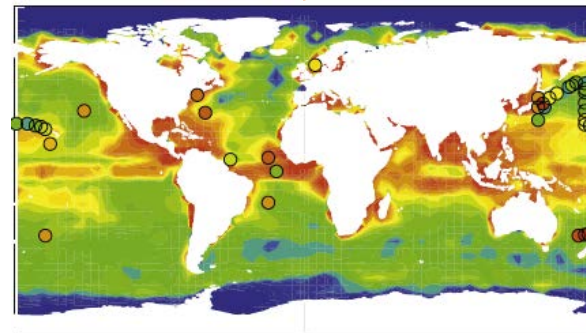

# Research Objectives

- Develop an online air-sea exchange model for mercury
- Interpret cruise observations
- Explore driving factors for air-sea exchange

# Models

Regrider

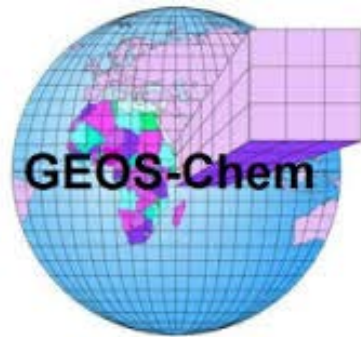

Hg<sup>II</sup> deposition flux,  
Atmospheric Hg<sup>0</sup> concentration

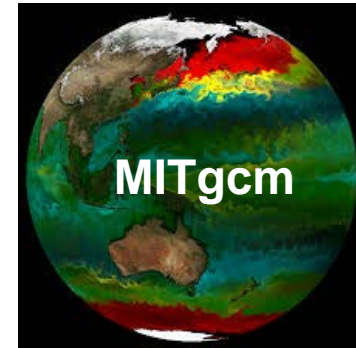

Net Hg<sup>0</sup> evasion flux

V9-02 (Horowitz et al, 2017)  
4x5 resolution, 47 layer  
GEOS5 (2008-2013)  
GEOSFP (2013-2017)  
Hourly time step

V1.27 (Zhang et al, in prep)  
1x1 resolution, 50 layer  
ERA-INTERIM (1992-2017)  
ECCO v4 (1992-2017)  
Hourly time step

# Results

01-Jan-2014, Hg0 Evasion,  $\text{kg m}^{-2}\text{s}^{-1}$

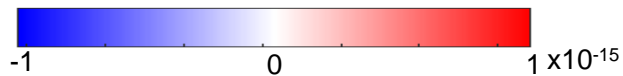
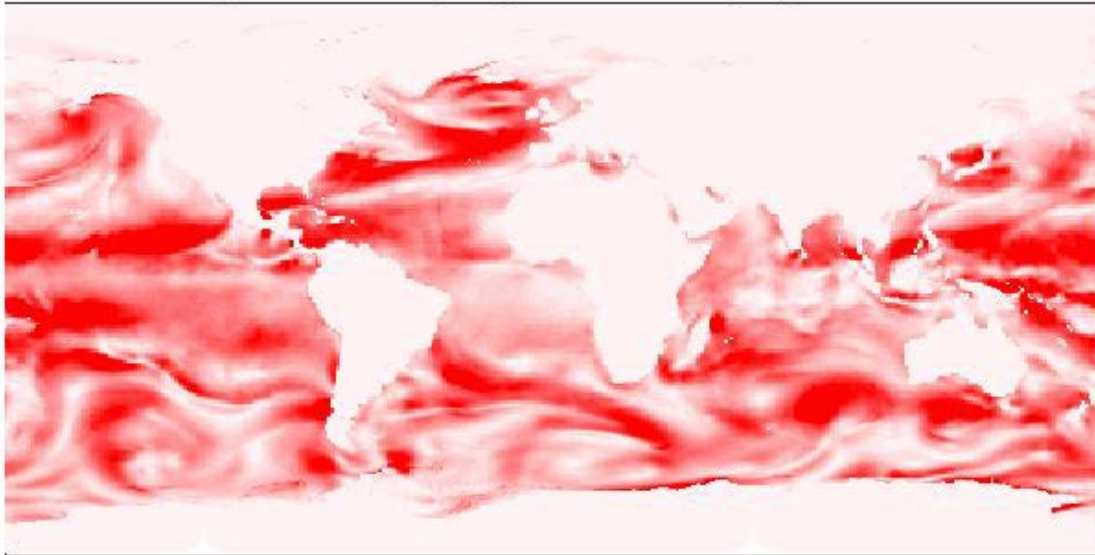

- Air-sea exchange is highly episodic, influenced by cyclone
- Resolution dependent: 1x1 is ~10% than 4x5 model

# Comparison with observations: tropical ocean

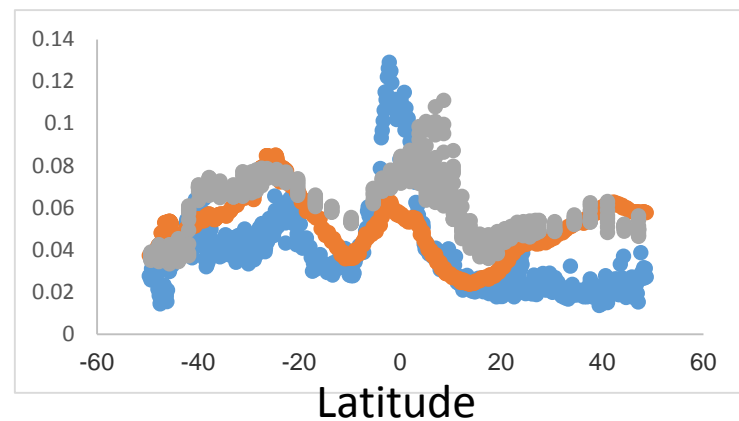
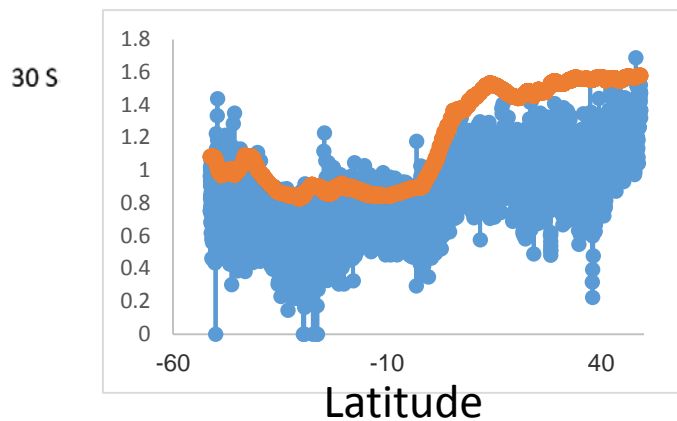
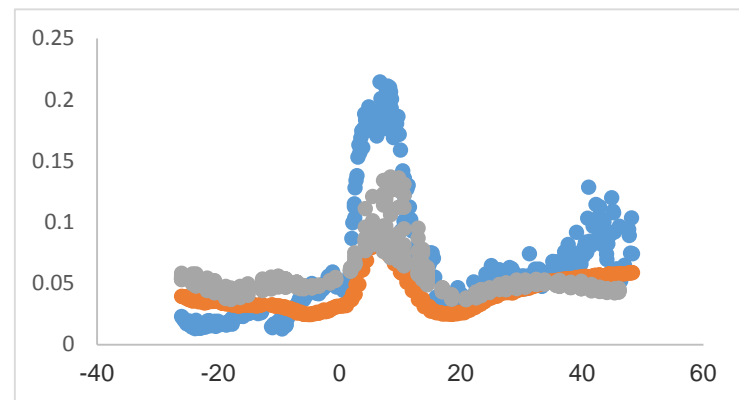
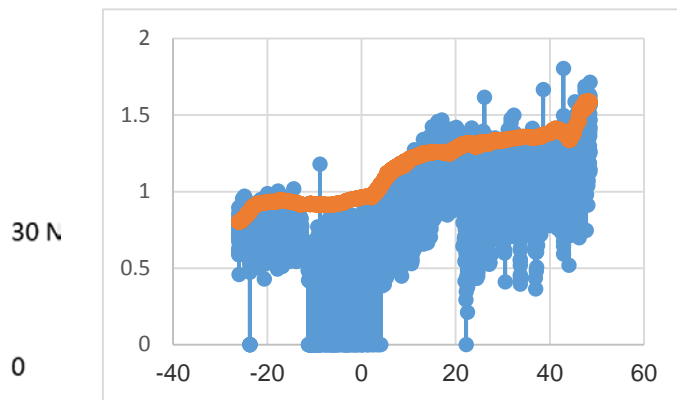
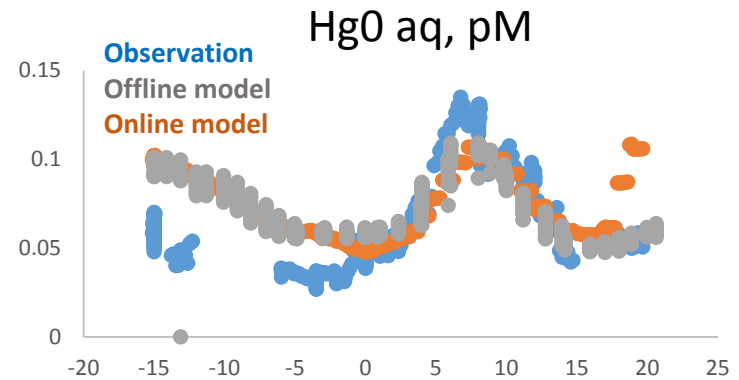
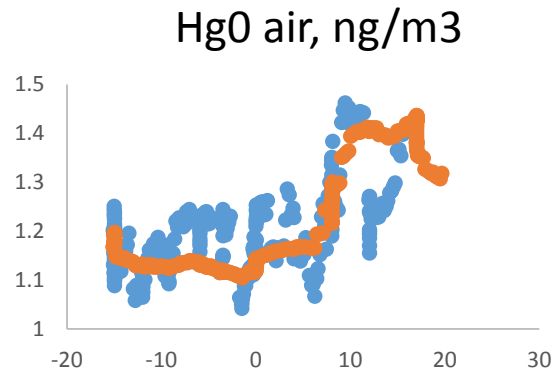
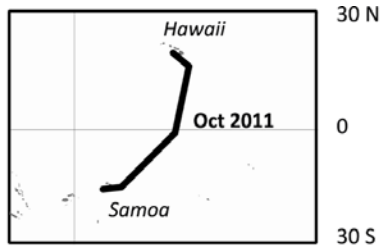

# Comparison with observations: tropical ocean

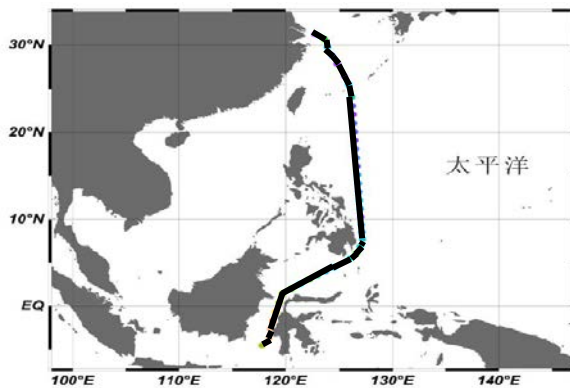

Apr, 2017

Observation  
Online model

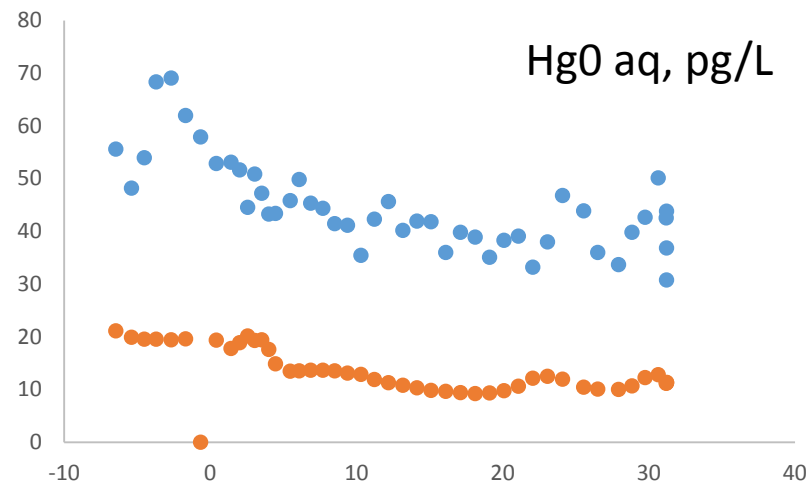
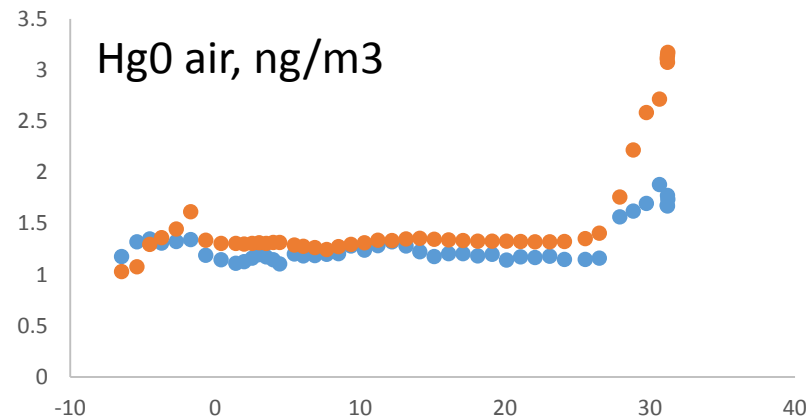

Latitude

# Comparison with observations: Southern Ocean

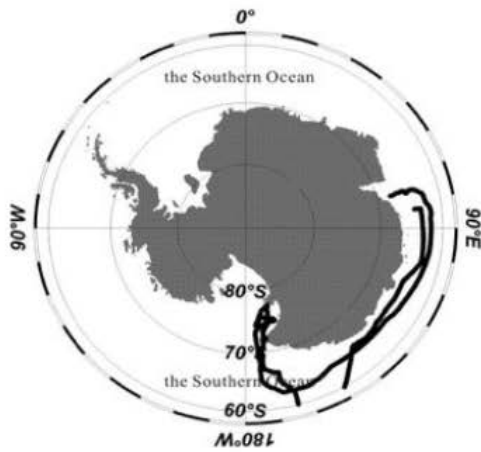

Dec, 2014 –  
Jan, 2015

Observation  
Online model

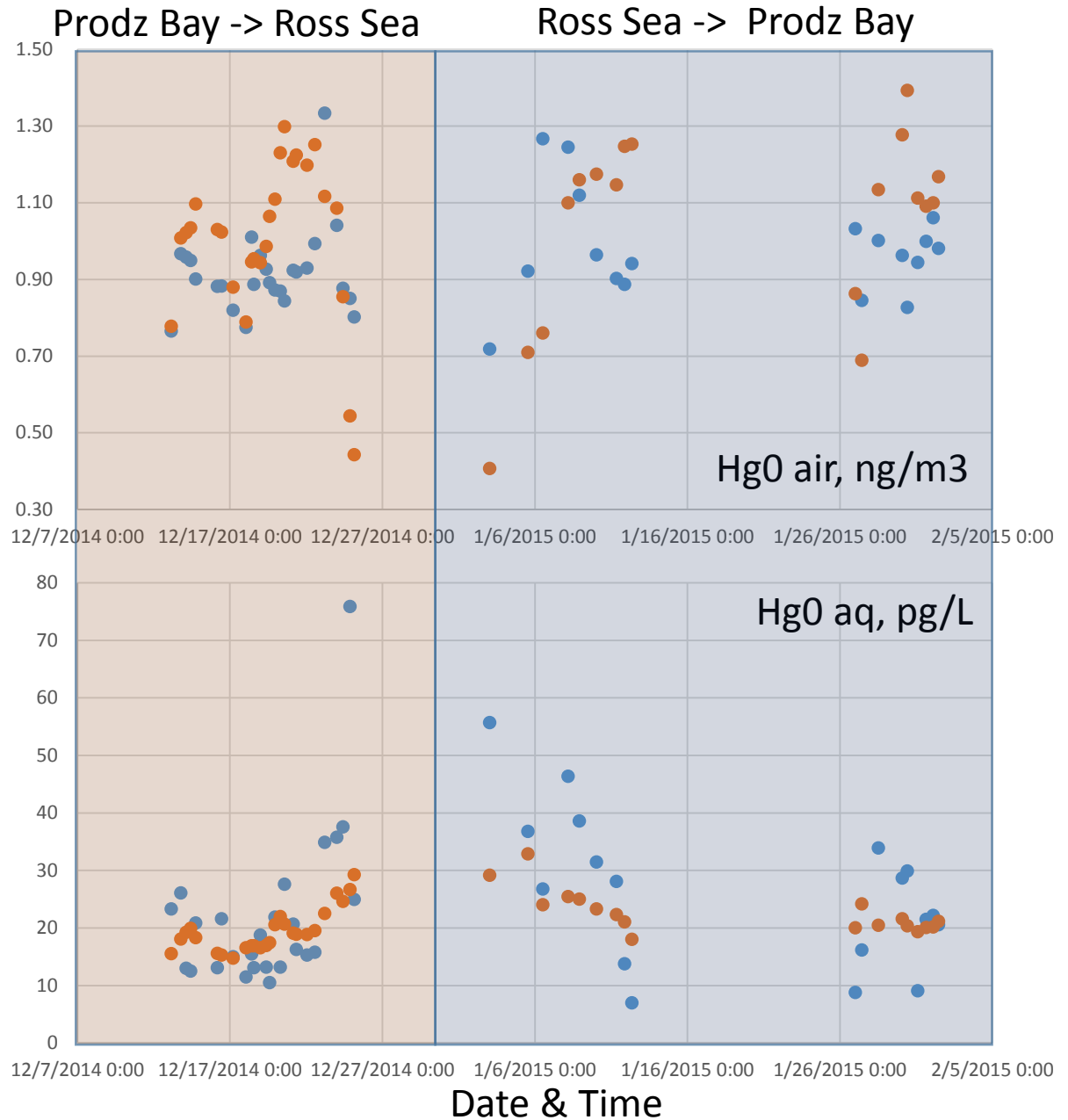

# Hg0aq vs instantaneous precipitation

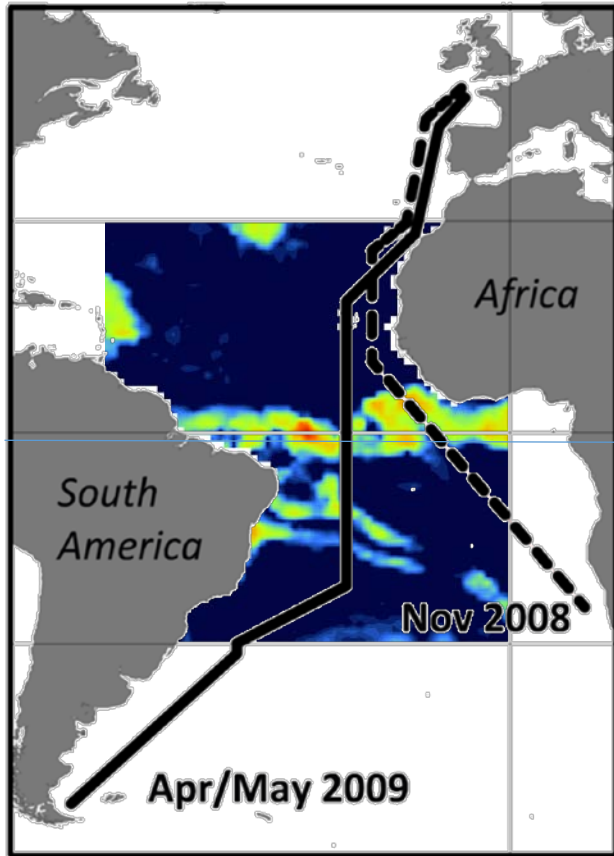

Precipitation over May 4, 2009 18:00 2°S (peak time)

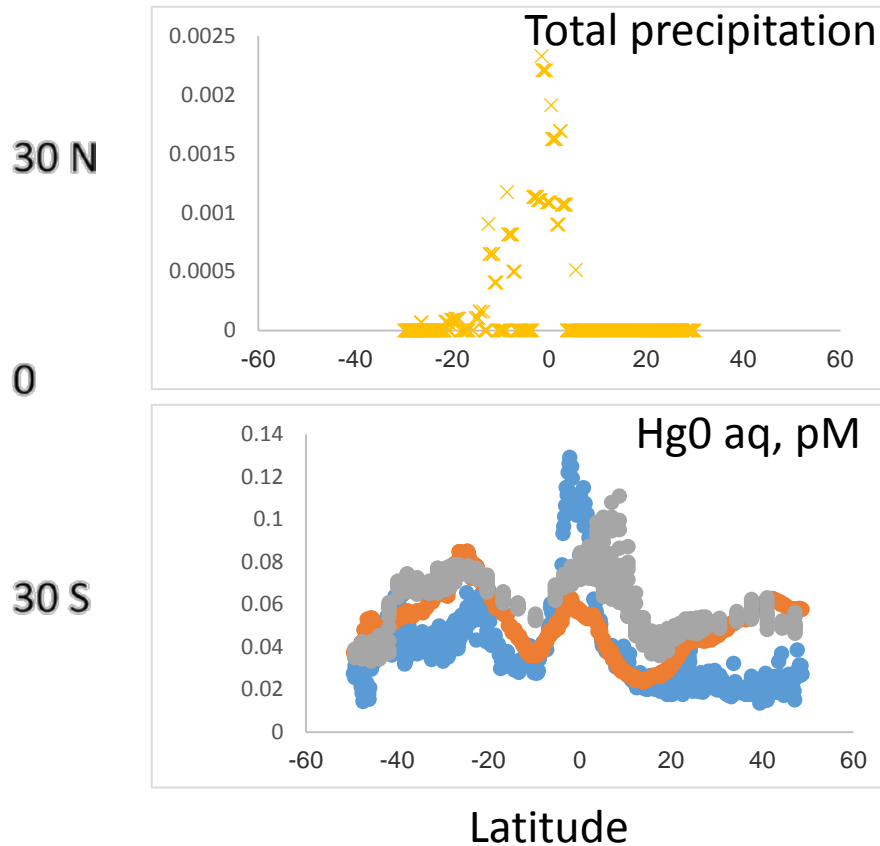

Hg0aq data well correlated with instantaneous 6-hour precipitation data

# Deposition as wet or dry

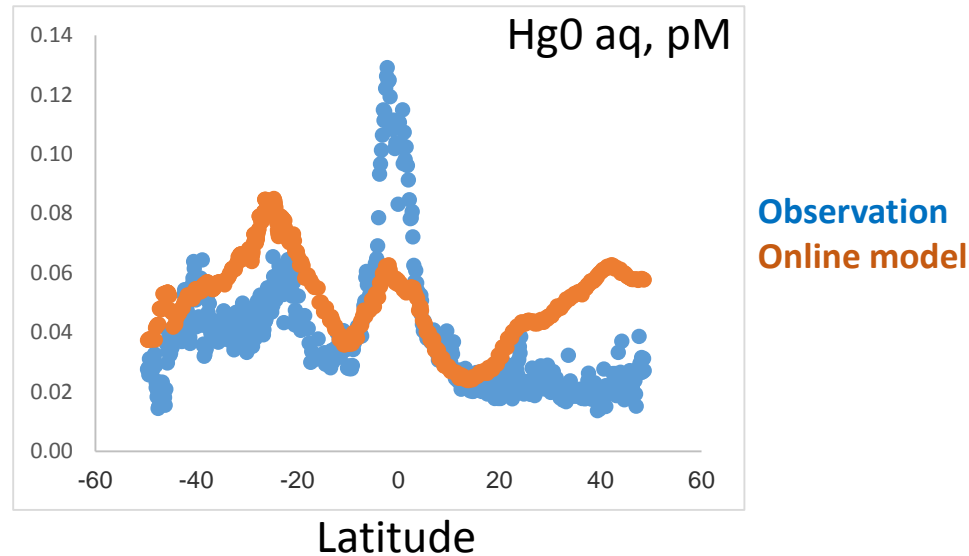

Model underestimates high concentration peaks but overestimates lower concentration regions:

Hg<sup>II</sup> wet deposition

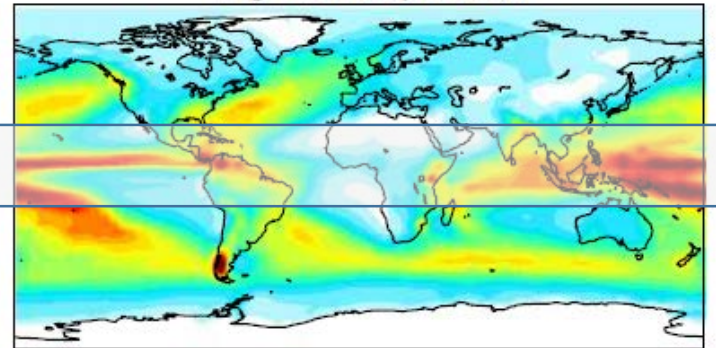

Convective rain scavenging

- Bias low tropical Pacific & Atlantic
- Bias high or okay at Middle and high latitudes

Hg<sup>II</sup> dry deposition

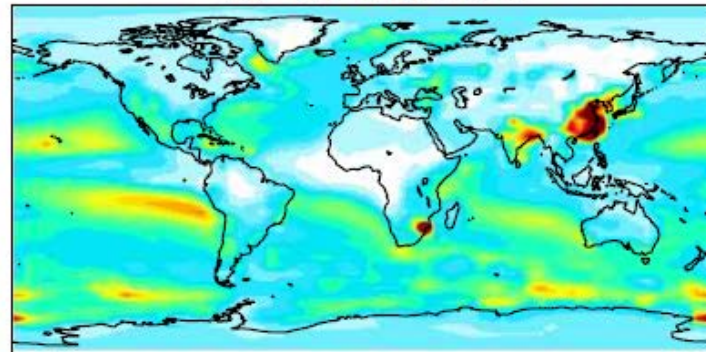

Loss via sea salt & gas/particle partitioning

- Double counting
- Rate-limited & instant equilibrium

# Acknowledgements

Jiancheng Wang and Zhouqing Xie from USTC  
Anne Soerensen from Stokholm University  
Joachim Kuss from Leibniz Institute for Baltic Sea  
  
Funding support from Nanjing University

**谢谢！**

# Nonlinearity in piston velocity calculation

4x5 resolution

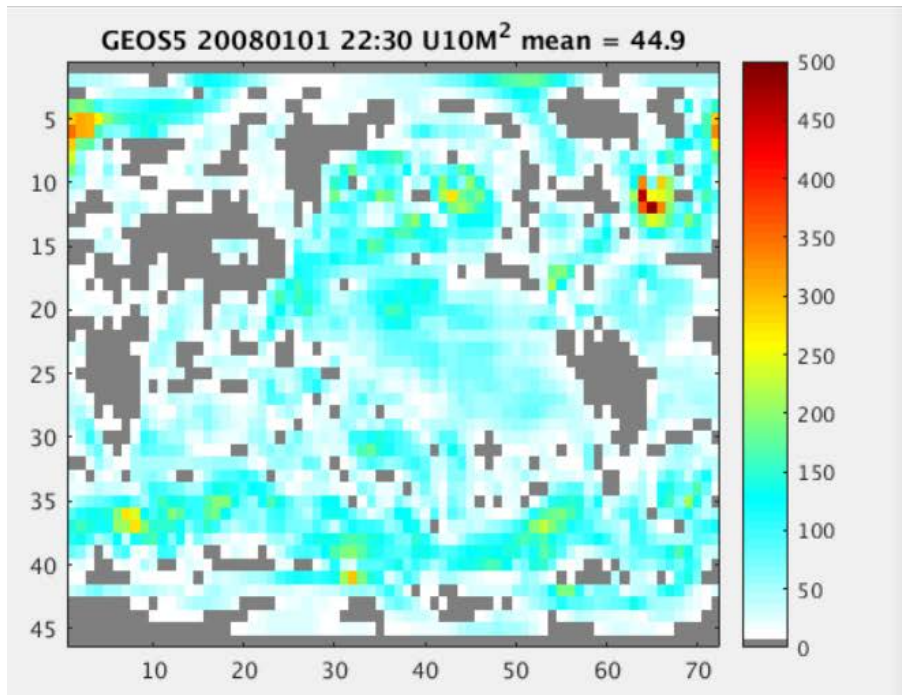

0.7x0.7 resolution

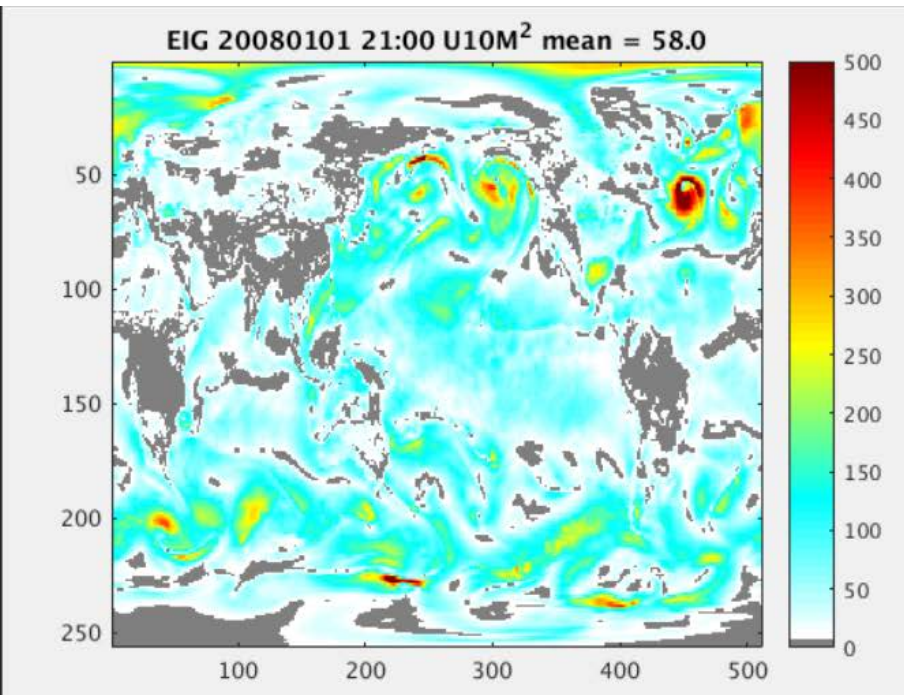

# Air-sea exchange of mercury

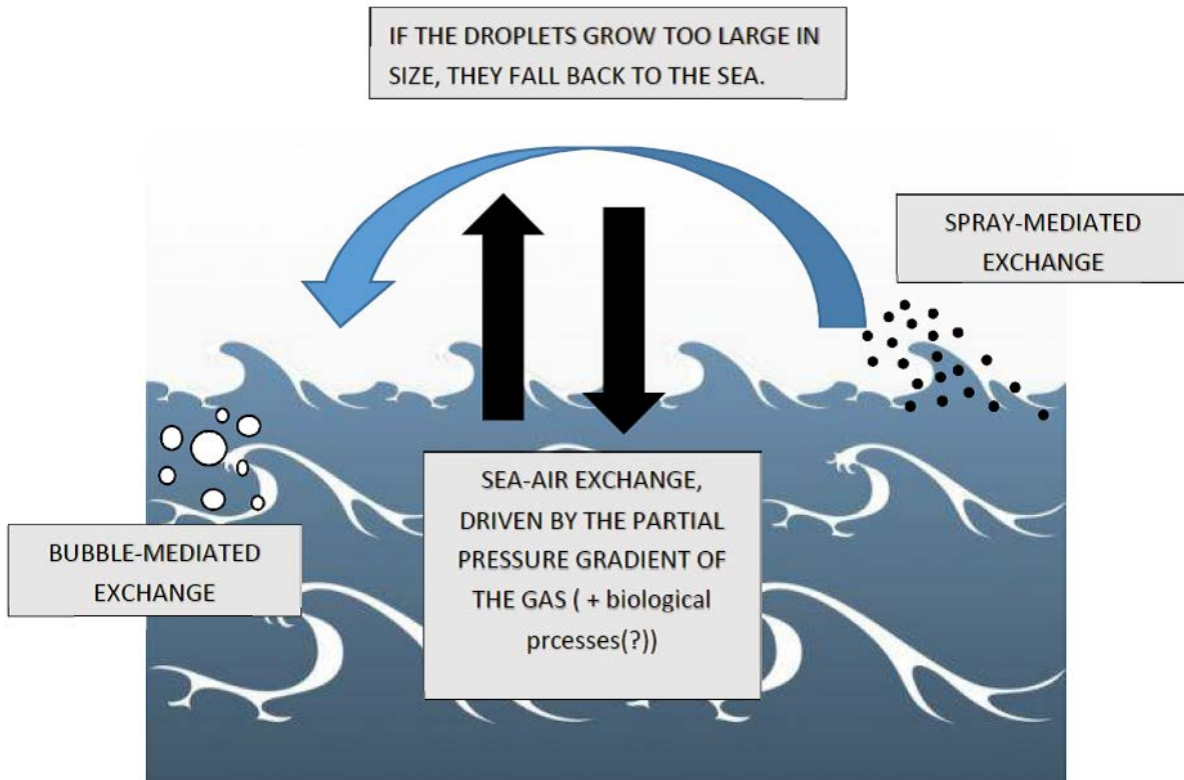

$$F = k_w(C_{\text{air}} - C_{\text{water}}/H)$$

F: Exchange flux

$K_w$  : Piston velocity

C :  $[\text{Hg}^0]$

H : Henry's Law constant

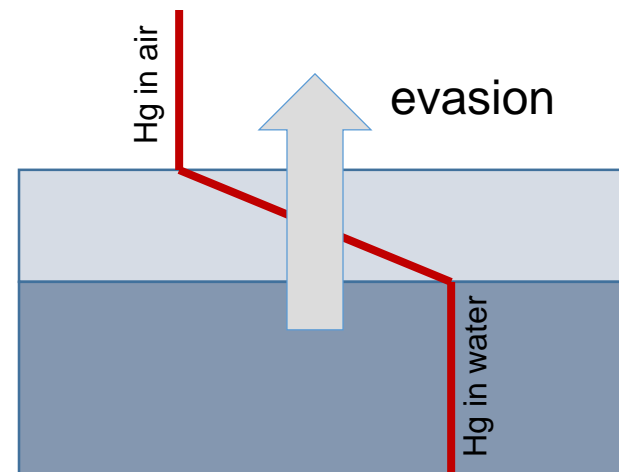

- Multiple pathways: gas exchange, bubbles, spray
- Gas exchange: controlled by concentration gradient
- Piston velocity: influenced by wind speed, wave, etc. ( $\propto U^2$ )

# Correlation between rain and Hg0aq

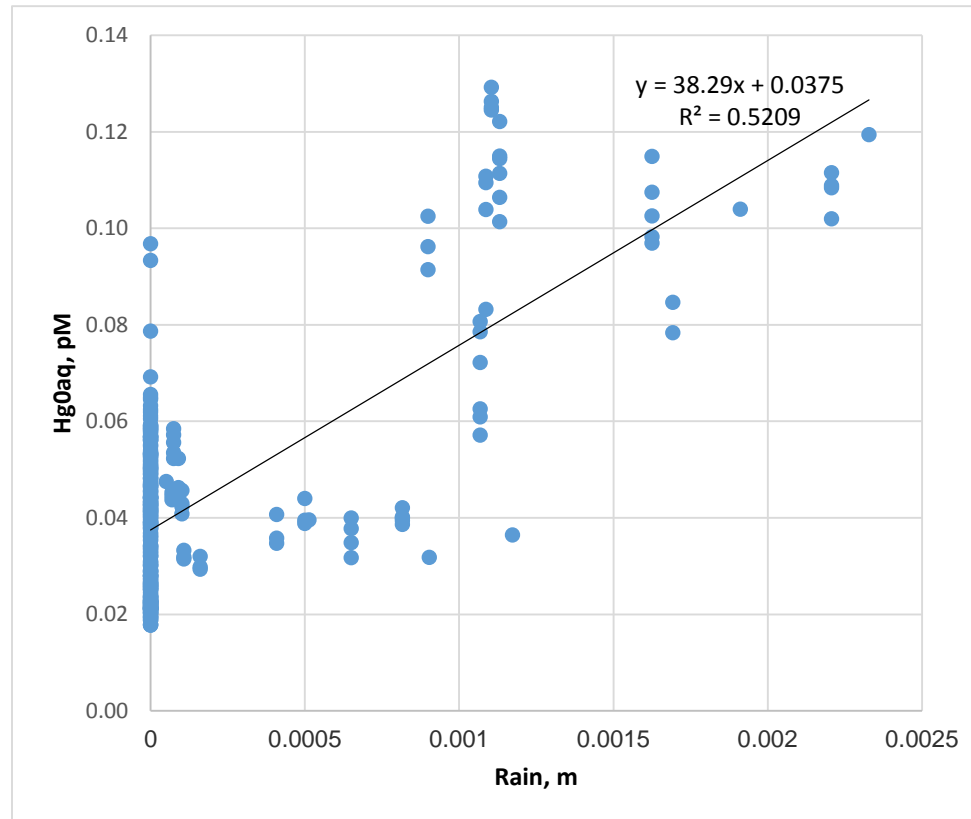

# Deposition 4x5 -> 1x1?

Scale deposition flux (4x5) by instantaneous rain (1x1) data?

